

Proposed Part 8 Residential Development
Balally, Sandyford

WIND MICROCLIMATE MODELLING

Dún Laoghaire – Rathdown County Council

Prepared by: B-Fluid Ltd. | Buildings Fluid Dynamics Consultants

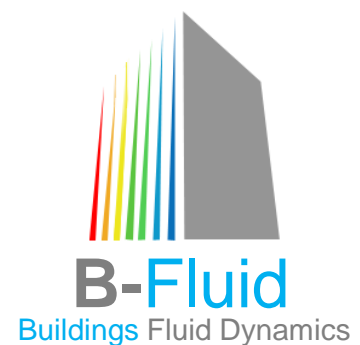

Document Reference		
Project Name	WIND MICROCLIMATE MODELLING	
Project Ref.	W_2309492	
Site location	Balally, Blackthorn Drive, Sandyford, Dublin 16	
CFD Study by	B-Fluid Ltd.	
Engineers	Dr. Cristina Paduano CFD Modelling Specialist CEng MIEI, PhD. Mech Eng., MEng. Aerospace Eng.	
	<table border="1"> <tr> <td>Dr. Arman Safdari CFD Modelling Specialist PhD. MEng, MSc. Mech.Eng.</td> <td>Filip Volaric CFD Modelling Specialist MSc. Mech.Eng.</td> </tr> </table>	Dr. Arman Safdari CFD Modelling Specialist PhD. MEng, MSc. Mech.Eng.
Dr. Arman Safdari CFD Modelling Specialist PhD. MEng, MSc. Mech.Eng.	Filip Volaric CFD Modelling Specialist MSc. Mech.Eng.	
Report issued on	February 19, 2024	

© 2024 Copyright B-Fluid Ltd.

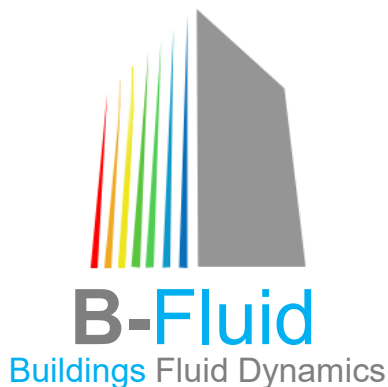

B-Fluid Ltd. | Buildings Fluid Dynamic Consultants

Ireland: The Studio, 55C Maple Avenue, Stillorgan, Dublin, A94 HY83
t: +353 (0)1 506 5671 m: +353 (0)85 713 6352

UK: Harwell Innovation Centre, 173 Curie Avenue, Didcot, OX11 0QG
t: +44 (0) 870 489 0207

Email: info@b-fluid.com

Website: www.b-fluid.com

Contents

1	EXECUTIVE SUMMARY	1
2	INTRODUCTION	1
2.1	GUIDANCE and LEGISLATION	4
2.2	URBAN WIND EFFECTS	5
3	ASSESSMENT METHODOLOGY	7
3.1	METHOD OF ASSESSMENT	8
3.2	ACCEPTANCE CRITERIA	10
3.3	SIGNIFICANCE CRITERIA	13
4	CFD MODELLING METHOD	15
4.1	INTRODUCTION OF CFD TECHNIQUE	16
4.2	CFD SOFTWARE DETAILS	17
4.3	CFD MODEL DETAILS	17
4.3.1	FLOW ASSUMPTIONS & TURBULENCE MODELLING	17
4.3.2	MODELED GEOMETRIES	17
4.3.3	COMPUTATIONAL MESH	18
4.3.4	BOUNDARY CONDITIONS	18
4.3.5	NUMERICAL CONFIGURATIONS	19
4.3.6	PARALLEL CONFIGURATIONS	19

5	LOCAL WIND CLIMATE	20
5.1	THE EXISTING RECEIVING ENVIRONMENT	21
5.1.1	SITE LOCATION AND SURROUNDING AREA	21
5.1.2	TOPOGRAPHY AND BUILT IN ENVIRONMENT	22
5.2	LOCAL WIND CONDITIONS	22
6	CHARACTERISTICS OF THE PROPOSED DEVELOPMENT	28
6.1	DESCRIPTION OF THE PROPOSED DEVELOPMENT	29
6.2	POTENTIAL RECEPTORS	30
7	BASELINE WIND MICROCLIMATE	31
7.1	BASELINE SCENARIO	32
7.1.1	WIND SPEEDS - PEDESTRIAN LEVEL	32
7.1.2	BASELINE WIND MICROCLIMATE - LAWSON CRITERIA	39
8	IMPACT OF THE PROPOSED DEVELOPMENT	41
8.1	CONSTRUCTION PHASE	42
8.2	OPERATIONAL PHASE	42
8.2.1	WIND SPEEDS - PEDESTRIAN LEVEL	43
8.2.2	PROPOSED DEVELOPMENT WIND MICROCLIMATE - LAWSON CRITERIA ..	49
8.2.3	BALCONIES	50
8.2.4	PLANNED MITIGATION	51
9	CONCLUSIONS	59
10	REFERENCES	62

1. EXECUTIVE SUMMARY

B-Fluid Limited has been commissioned to perform a Wind Microclimate Study for the Proposed Part 8 Residential Development in Balally, Blackthorn Drive, Sandyford, Dublin 16. This report is prepared on behalf of the NDFA and Dun Laoghaire County Council.

Figure 1.1 shows a view of the proposed development (in colour) within the existing urban context.



Figure 1.1: Proposed Part 8 Residential Development

The method for the study of wind microclimate combines the use of Computational Fluid Dynamics (CFD) to predict wind velocities and wind flow patterns, with the use of wind data from suitable meteorological station and the recommended comfort and safety standards (Lawson Criteria).

The effect of the geometry, height and massing of the proposed development and existing surroundings including topography, ground roughness and landscaping of the site, on local wind speed and direction is considered as well as the pedestrian activity to be expected (sitting, standing, strolling and fast walking).

The results of the assessment are presented in the form of contours of the Lawson criteria at pedestrian level.

The assessment has comprised the following scenarios:

- **Baseline Existing Scenario:** this consist of the existing wind microclimate at the site. Figure 1.2 shows a view of the existing surrounding buildings (in grey).



Figure 1.2: Buildings in the Baseline Scenario (Existing buildings in grey)

- **Proposed Development Scenario:** this consist of the assessment of the wind microclimate of the site with the proposed development surrounded by existing buildings. Figure 1.3 shows a view of the buildings in the proposed development and existing surrounding buildings (in grey).



Figure 1.3: Buildings in the Proposed Scenario (Proposed Part 8 Residential development and existing buildings in grey)

Based on the analysis conducted, it can be concluded that:

- The wind profile was built using the annual average meteorological data for Dublin Airport, which was obtained from Meteoblue. The local wind speed was determined from CFD simulations with combination of the parameters inside Weibull probability distribution function, which was obtained from historical meteorological data recorded 10m above ground level.
- A 12-discrete set of wind direction is used in order to evaluate the probability of exceedance at any given threshold speed. It is found that the prevailing wind direction in the West has the largest contribution of the discomfort exceedance probability.
- The microclimate Assessment of Proposed Part 8 Residential Development and its environment was performed utilizing a CFD (Computational Fluid Dynamics) methodology.
- The evaluation of the proposed scenario indicates that the planned development aligns with the Lawson Comfort Criteria, confirming that no areas are unsafe and the proposed development does not create conditions of distress. All the ground and the courtyard amenities outlined in the report can be utilized according to their intended scope.
- The Lawson Comfort and Distress Map on 1.5m above the balcony floor indicates that all balconies are safe for occupants because there are no identified distress areas.
- In addition to the already favourable pedestrian comfort conditions, the following mitigation measures are implemented to improve pedestrian comfort around the development:
 - Preserving the existing trees along the walkway on the West side of the development;
 - Introducing additional hedge planting along the western and northern walls of the walkway;
 - Planting additional trees on the South-West side of the development;
 - Additional trees on the North-West side of the development;
 - The balcony railings are acting as wind deflectors, helping to reduce the impact of wind. This shows that the balconies are designed with considerations for prevailing wind directions;
 - The balconies also function as windbreaks, providing additional shelter to pedestrians by blocking or reducing the downwash or corner effects of wind that arrives at ground level.
- As a result of the proposed development construction, the wind on the surrounding urban context remains suitable for the intended use when compared with the baseline situation.
- The proposed development does not impact or give rise to negative or critical wind speed profiles at the nearby adjacent roads, or nearby buildings. Moreover, in terms of distress, no critical conditions were found for “Frail persons or cyclists” and for members of the “General Public” in the surrounding of the development.

2. INTRODUCTION

B-Fluid Limited has been commissioned to perform a Wind Microclimate Study for the Proposed Part 8 Residential Development in Balally, Blackthorn Drive, Sandyford, Dublin 16. This report is prepared on behalf of the NDFA and Dun Laoghaire County Council.

Figure 2.1 shows a view of the proposed development within the existing urban context.



Figure 2.1: Proposed Part 8 Residential Development (Coloured)

This report is completed by Dr. Cristina Paduano, Dr. Arman Safdari , and Filip Volaric.

Dr. Cristina Paduano is a Chartered Engineer (CEng) and member of Engineers Ireland who specialises in computational fluid dynamics applications for urban environment and the construction industry with over 18 years experience. She holds a PhD in Mechanical Engineering from Trinity College Dublin, with M.Eng and B.Eng in Aerospace Engineering.

Dr. Arman Safdari, a CFD Modelling Engineer and member of Engineers Ireland, specialises in computational fluid dynamics applications. His expertise lies in airflow modeling, heat and mass transfer, as well as multi-phase flow simulations. He earned his PhD in Mechanical Engineering from Pusan National University, followed by a M.Sc. and B.Sc. in Mechanical Engineering.

Filip Volaric is CFD Modelling Engineer who specialises in computational fluid dynamics applications. He is an expert in heat and mass transfer and structural analysis. He holds a M.Sc. and B.Sc. in Mechanical Engineering and is finishing PhD in Mechanical Engineering at University College Dublin.

A wind microclimate study considers the possible wind patterns formed under both mean and peak wind conditions typically occurring on the site area, accounting for a scenario where the proposed development is inserted in the existing environment (potential impact) and, for a scenario where the proposed development is analysed together with the existing environment and any permitted development (not constructed yet) that can be influenced by the wind patterns generated by the proposed one (cumulative impact).

The potential receptors include those areas, in the surrounding of the development, which can be exposed to potential risks generated by the elevated wind speed or building massing wind effects. In particular:

- Amenity areas (pedestrian level), areas likely to be utilised for leisure purposes and as such should be comfortable surroundings.
- Pedestrian routes and seating areas – to determine if locations are comfortable for leisure activities.
- Entrance to the buildings – to determine if there is potential for pressure related issues for entrances or lobbies.
- Landscaped areas – where there are sheltered areas.
- Impact to existing or adjoining developments – where the proposed buildings will cause discomfort conditions through proximity related issues.

The acceptance criteria which define the acceptable wind velocities in relation to the perception of comfort level experienced while carrying out a specific pedestrian activity is known as the “Lawson Criteria for Pedestrian Comfort and Distress”. A wind microclimate study analyses the wind flow in an urban context (considering the wind conditions typically occurring on the site during a typical year) to develop the so called “Lawson Comfort and Distress Map”; the map identifies where a specific pedestrian activity can be carried out comfortably during most of the time.

The assessment can be performed by physical testing in wind tunnels or by performing “virtual wind tunnel testing” through numerical simulation using Computational Fluid Dynamics (CFD), as done for this project. The scope of the numerical study is to simulate the wind around the development, in order to predict the wind speeds the pedestrians will be exposed to and the level of comfort they will experience when carrying out a specific activity (i.e. walking, strolling, sitting).

The following sections details the methodology, acceptance criteria, CFD wind simulations and the impact of the proposed development on the local wind microclimate against best practice guidelines for pedestrian comfort and safety.

2.1 GUIDANCE and LEGISLATION

According to the ‘Urban Development and Building Heights, Guidelines for Planning Authorities (Government of Ireland, December 2020)’ document, specific wind impact assessment of the microclimatic effects should be performed for ‘buildings taller than prevailing building heights in urban areas’. In the same guidance, standard buildings height is considered 6-8 storeys. Above this height, buildings are considered ‘taller’.

The recommended approach to wind microclimate studies is outlined in the “Wind Microclimate Guidelines for Developments in the City of London ‘(August 2019) and in the guidelines and recommendations contained in BRE Digest (DG) 520, “Wind Microclimate Around Buildings” (BRE, 2011). The Lawson Criteria of Comfort and Distress is used to benchmark the pedestrian wind microclimate.

The document also indicates how to use Computational fluid dynamics (CFD) to assess wind microclimate conditions and how to generate high quality outputs to provide a good understanding of the fundamental flow features around an urban context.

Usually, the recommended approach to wind microclimate studies is based on the building height, as presented in Figure 2.2.

Building Height	Recommended Approach to Wind Microclimate Studies
Similar or lower than the average height of surrounding buildings Up to 25m	Wind studies are not required, unless sensitive pedestrian activities are intended (e.g. around hospitals, transport hubs, etc.) or the project is located on an exposed location
Up to double the average height of surrounding buildings 25m to 50m	Computational Fluid Dynamics (CFD) Simulations OR Wind Tunnel Testing
Up to 4 times the average height of surrounding buildings 50m to 100m	Computational Fluid Dynamics (CFD) Simulations AND Wind Tunnel Testing
High Rise Above 100m	Early-Stage Massing Optimization: Wind Tunnel Testing OR Computational Fluid Dynamics (CFD) Simulations Detailed Design: Wind Tunnel Testing AND Computational Fluid Dynamics (CFD) Simulations

Figure 2.2: Recommended Approach to Wind Microclimate Studies based on Building Height, as prescribed by the Wind Microclimate Guidelines for Developments in the City of London (August 2019)

2.2 URBAN WIND EFFECTS

Buildings and topography affect the speed and direction of wind flows. Wind speed increases with increasing height above the ground, assuming a parabolic profile.

Flow near the ground level encounters obstacles represented by terrain roughness/buildings that reduce the wind speed and introduce random vertical and horizontal velocity components. This turbulence causes vertical mixing between the air moving horizontally at one level, and the air at those levels immediately above and below it. For this reason, the wind velocity profile is given by a fluctuating velocity along a mean velocity value. Figure 2.3 shows the wind velocity profile, as described above.

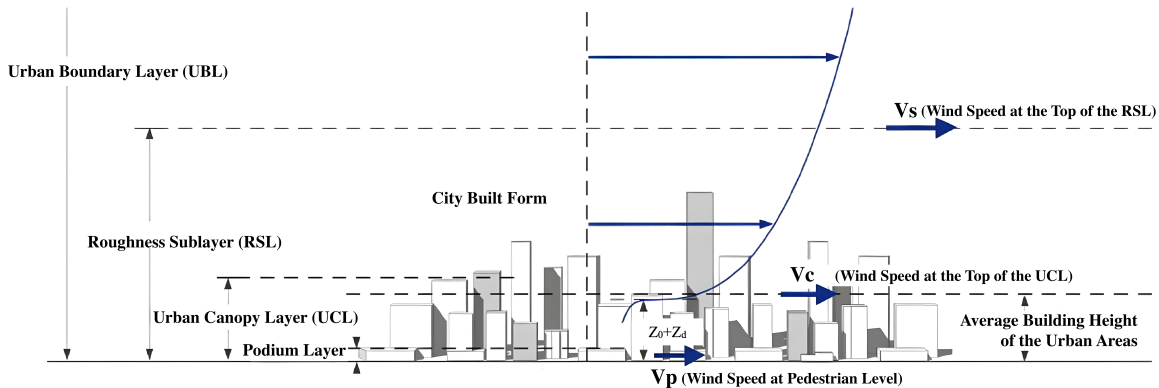

Figure 2.3: Wind Velocity Profile

In an urban context, wind speeds at pedestrian level are generally low compared with upper-level wind speeds, however, the wind can create adverse patterns when flowing in between buildings which can cause local wind accelerations or re-circulations. This wind patterns effect pedestrian safety and comfort. In general, the wind effects to be avoided/mitigated in an urban context include the following:

- **Funnelling Effects:** The wind can accelerate significantly when flowing through a narrow passage between building structures. The highest speeds are experienced at the point where the restriction of the area is the greatest.
- **Downwash Effects:** The air stream when striking a tall building can flow around it, over it and a part can be deflected towards the ground. This downward component is called downwash effect and its intensity depends on the pressure difference driving the wind. The higher the building, the higher this pressure difference can be.
- **Corner Effects:** Wind can accelerate around the corners of the buildings. Pedestrians can experience higher wind speeds as well as more sudden changes in wind speeds. The reason for this is that there are narrow transition zones between the accelerated flows and the adjacent quiescent regions. This effect is linked to the downwash effect as the downward stream component subsequently flows around the corners towards the leeward side of the building.

- **Wake Effect:** Excessive turbulence can occur in the leeward side of the building. This can cause sudden changes in wind velocity and can raise dust or lead to accumulation of debris. This effect is also dependent on the height of the building.

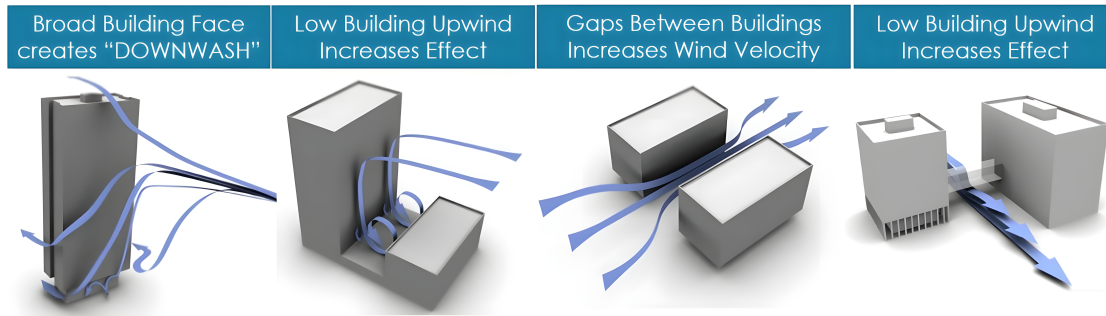

Figure 2.4: Parameters to know for Wind Conditions Assessment

The anticipation of the likely wind conditions resulting from new developments are important considerations in the context of pedestrian comfort and the safe use of the public realm. While it is not always practical to design out all the risks associated with the wind environment, it is possible to provide local mitigation to minimise risk or discomfort where required.

3. ASSESSMENT METHODOLOGY

3.1 METHOD OF ASSESSMENT

The method for the study of wind microclimate combines the use of Computational Fluid Dynamics (CFD) to predict wind velocities and wind flow patterns, with the use of wind data from suitable meteorological station and the recommended comfort and safety standards (Lawson Criteria). The effect of the geometry, height and massing of the proposed development and existing surroundings including topography, ground roughness and landscaping of the site, on local wind speed and direction is considered as well as the pedestrian activity to be expected (sitting, standing, strolling and fast walking). The results of the assessment are presented in the form of contours of the Lawson criteria at pedestrian level.

The assessment has comprised the following scenarios:

- **Baseline Existing Scenario:** this consists of the existing wind microclimate at the site.
- **Proposed Development in the Existing Scenario:** this consists of the assessment of the wind microclimate of the site with the proposed development surrounded by existing buildings.

In accordance with the guideline cited in section 1.1, the wind microclimate study should consider the effect of the proposed development together with buildings (existing and/or permitted) that are within 500m from the centre of the site, as shown in Figures 3.1 and 3.2. Other taller buildings outside of this zone that could have an influence on wind conditions within the project site should be included for wind directions where they are upwind of the project site.

In particular, the following has been undertaken:

- Topography of the site with buildings (proposed and adjacent existing/permitted developments massing, depending on the scenario assessed “baseline or proposed”) have been modelled using OpenFOAM Software.
- Suitable wind conditions have been determined based on historic wind data. Criteria and selected wind scenarios included means and peaks wind conditions that need to be assessed in relation to the Lawson Criteria.
- Computational Fluid Dynamics (CFD) has been used to simulate the local wind environment for the required scenarios (“baseline, proposed”).
- The impact of the proposed development massing on the local wind environment has been determined (showing the wind flows obtained at pedestrian level).
- Potential receptors (pedestrian areas) have been assessed through review of external amenity/public areas (generating the Lawson Comfort and Distress Map).
- Potential mitigation strategies for any building related discomfort conditions (where necessary) have been explored and their effect introduced in the CFD model produced.



Figure 3.1: Area of interest to be modelled

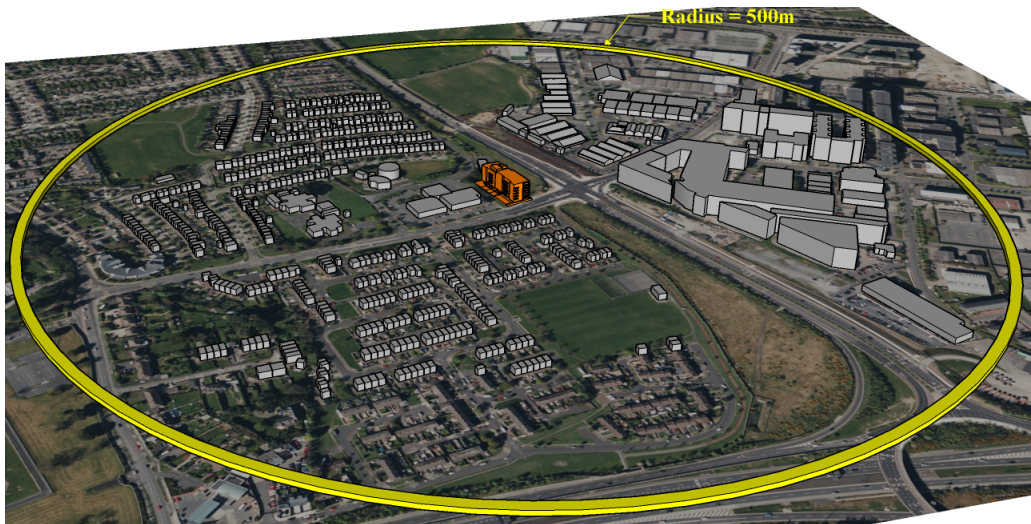

Figure 3.2: Area of interest to be modelled - side view

3.2 ACCEPTANCE CRITERIA

Pedestrian Wind Comfort is measured in function of the frequency of wind speed threshold exceeded based on the pedestrian activity. The assessment of pedestrian level wind conditions requires a standard against which measured or expected wind velocities can be compared.

Only gust winds are considered in the safety criterion. These are usually rare events, but deserve special attention in city planning and building design due to their potential impact on pedestrian safety. Gusts cause the majority of cases of annoyance and distress and are assessed in addition to average wind speeds. Gust speeds should be divided by 1.85 and these "gust equivalent mean" (GEM) speeds are compared to the same criteria as for the mean hourly wind speeds. This avoids the need for different criteria for mean and gust wind speeds.

The following criteria are widely accepted by municipal authorities as well as the international building design and city planning community:

- **DISCOMFORT CRITERIA:** Relates to the activity of the individual.
Onset of discomfort:
 - Depends on the activity in which the individual is engaged and is defined in terms of a mean hourly wind speed (or GEM) which is exceeded for 5% of the time.
- **DISTRESS CRITERIA:** Relates to the physical well-being of the individual.
Onset of distress:
 - ‘Frail Person Or Cyclist’: equivalent to an hourly mean speed of 15 m/s to be exceeded more than 0.023% per year. This is intended to identify wind conditions which less able individuals or cyclists may find physically difficult. Conditions in excess of this limit may be acceptable for optional routes and routes which less physically able individuals are unlikely to use.
 - ‘General Public’: A mean speed of 20 m/s or larger speed to be exceeded more than 0.023% per year, when aerodynamic forces approach body weight makes it impossible for anyone to remain standing. If wind speeds exceed these values, pedestrian access should be discouraged.

The above criteria set out six pedestrian activities and reflect the fact that calm activity requires calm wind conditions, which are summarised by the Lawson scale, shown in Figure 3.3. Lawson scale assesses pedestrian wind comfort in absolute terms and defines the reaction of an average person to the wind. Each wind type is associated to a number, corresponding to the Beaufort scale. Beaufort scale is an empirical measure that relates wind speed to observed conditions at sea or on land. A 20% exceedance is used in these criteria to determine the comfort category, which suggests that wind speeds would be comfortable for the corresponding activity at least 80% of the time or four out of five days.





Beaufort Scale	Wind Type	Mean Hourly Wind Speed (m/s)		Acceptance Level Based on Activity—Lawson Criteria			
				Sitting	Standing/ Entrances	Leisure Walking	Business Walking
0-1	Light Air	0 – 1.55	COMFORT	Acceptable	Tolerable	Not acceptable	Dangerous
2	Light Breeze	1.55 - 3.35		Acceptable	Tolerable	Not acceptable	Dangerous
3	Gentle Breeze	3.35 - 5.45		Acceptable	Tolerable	Not acceptable	Dangerous
4	Moderate	5.45 - 7.95		Acceptable	Tolerable	Not acceptable	Dangerous
5	Fresh Breeze	7.95 - 10.75		Acceptable	Tolerable	Not acceptable	Dangerous
6	Strong Breeze	10.75 - 13.85		Acceptable	Tolerable	Not acceptable	Dangerous
7	Near Gale	13.85 - 17.15		Acceptable	Tolerable	Not acceptable	Dangerous
8	Gale	17.15 - 20.75	DISTRESS	Not acceptable	Dangerous	Not acceptable	Dangerous
9	Strong Gale	20.75 - 24.45		Not acceptable	Dangerous	Not acceptable	Dangerous
Legend				Acceptable	Tolerable	Not acceptable	Dangerous
							

Figure 3.3: Lawson Scale

These criteria for wind forces represent average wind tolerances. They are subjective and variable depending on thermal conditions, age, health, clothing, etc. which can all affect a person’s perception of a local microclimate. Moreover, pedestrian activity alters between winter and summer months. The criteria assume that people will be suitably dressed for the time of year and individual activity. It is reasonable to assume, for instance, that areas designated for outdoor seating will not be used on the windiest days of the year. Weather data measured are used to calculate how often a given wind speed will occur each year over a specified area.

Pedestrian comfort criteria are assessed at 1.5m above ground level. Unless in extremely unusual circumstances, velocities at pedestrian level increase as you go higher from ground level.

A breach of the distress criteria requires a consideration of:

- whether the location is on a major route through the complex,
- whether there are suitable alternate routes which are not distressful.

If the predicted wind conditions exceed the threshold, then conditions are unacceptable for the type of pedestrian activity and mitigation measure should be implemented into the design.

Pedestrian Comfort Category (Lawson Scale)	Mean and Gem wind speed not to be exceeded more than 5% of the time	Description
Sitting	4m/s	Acceptable for frequent outdoor sitting use, i.e., restaurant /café
Standing	6m/s	Acceptable for occasional outdoor sitting use, i.e., public outdoor spaces
Walking/Strolling	8m/s	Acceptable for entrances/bus stops /covered walkaways
Business Walking	10m/s	Acceptable for external pavements, walkways
Unacceptable/Distress	>10m/s	Start of not comfortable/distress level for pedestrian access

Figure 3.4: Lawson Categories Scale - Comfort

Pedestrian Safety Category (Lawson Scale)	Mean and Gem wind speed not to be exceeded more than 0.0022% of the time	Description
Unsafe for public	>20m/s	Distress/safety concern for pedestrian
Unsafe for cyclists or frail person	>15m/s	Distress/safety concern for cyclist/frail person

Figure 3.5: Lawson Categories Scale - Distress/Safety

3.3 SIGNIFICANCE CRITERIA

The significance of on-site measurement locations are defined by comparing the wind comfort/safety levels with the intended pedestrian activity at each location, using the table provided by the Lawson Comfort and Distress Criteria.

The significance of off-site measurement locations are defined by comparing the wind comfort/safety levels with the intended pedestrian activity at each location, prior and after the introduction of the proposed development.

Significance	Trigger	Mitigation required?
Major Adverse	Conditions are “unsafe”	Yes
Moderate Adverse	Conditions are “unsuitable” (in terms of comfort) for the intended pedestrian use.	Yes
Negligible	Conditions are “suitable” for the intended pedestrian use.	No
Moderate Beneficial	Conditions are calmer than required for the intended pedestrian use (by at least one comfort category).	No

Figure 3.6: Significance Criteria for On-site Receptors

Significance	Trigger	Mitigation required?
Major Adverse	<p>Conditions that were “safe” in the baseline scenario became “unsafe” as a result of the Proposed Development.</p> <p><i>OR</i></p> <p>Conditions that were “suitable” in terms of comfort in the baseline scenario became “unsuitable” because of the Proposed Development.</p> <p><i>OR</i></p> <p>Conditions that were “unsafe” in the baseline scenario are made worse because of the Proposed Development.</p>	Yes
Moderate Adverse	<p>Conditions that were “suitable” in terms of comfort in the baseline scenario are made windier (by at least one comfort category) as a result of the Proposed Development but remain “suitable” for the intended pedestrian activity.</p>	No
Negligible	<p>Conditions remain the same as in the baseline scenario.</p>	No
Major Beneficial	<p>Conditions that were “unsafe” in the baseline scenario became “safe” because of the Proposed Development.</p>	No
Moderate Beneficial Potential Receptors	<p>Conditions that were “unsuitable” in terms of comfort in the baseline scenario became “suitable” because of the Proposed Development.</p> <p><i>OR</i></p> <p>Conditions that were “unsafe” in the baseline scenario are made better as a result of the Proposed Development (but not so as to make them “safe”).</p>	No

Figure 3.7: Significance Criteria for Off-site Receptors

4. CFD MODELLING METHOD

4.1 INTRODUCTION OF CFD TECHNIQUE

Computational Fluid Dynamics (CFD) is a numerical technique to simulate fluid flow, heat and mass transfer, chemical reaction and combustion, multiphase flow, and other phenomena related to fluid flows. CFD modelling includes three main stage: pre-processing, simulation and post-processing as described in Figure 4.1. The Navier-Stokes equations, used within CFD analysis, are based entirely on the application of fundamental laws of physics and therefore produce extremely accurate results providing that the scenario modelled is a good representation of reality.

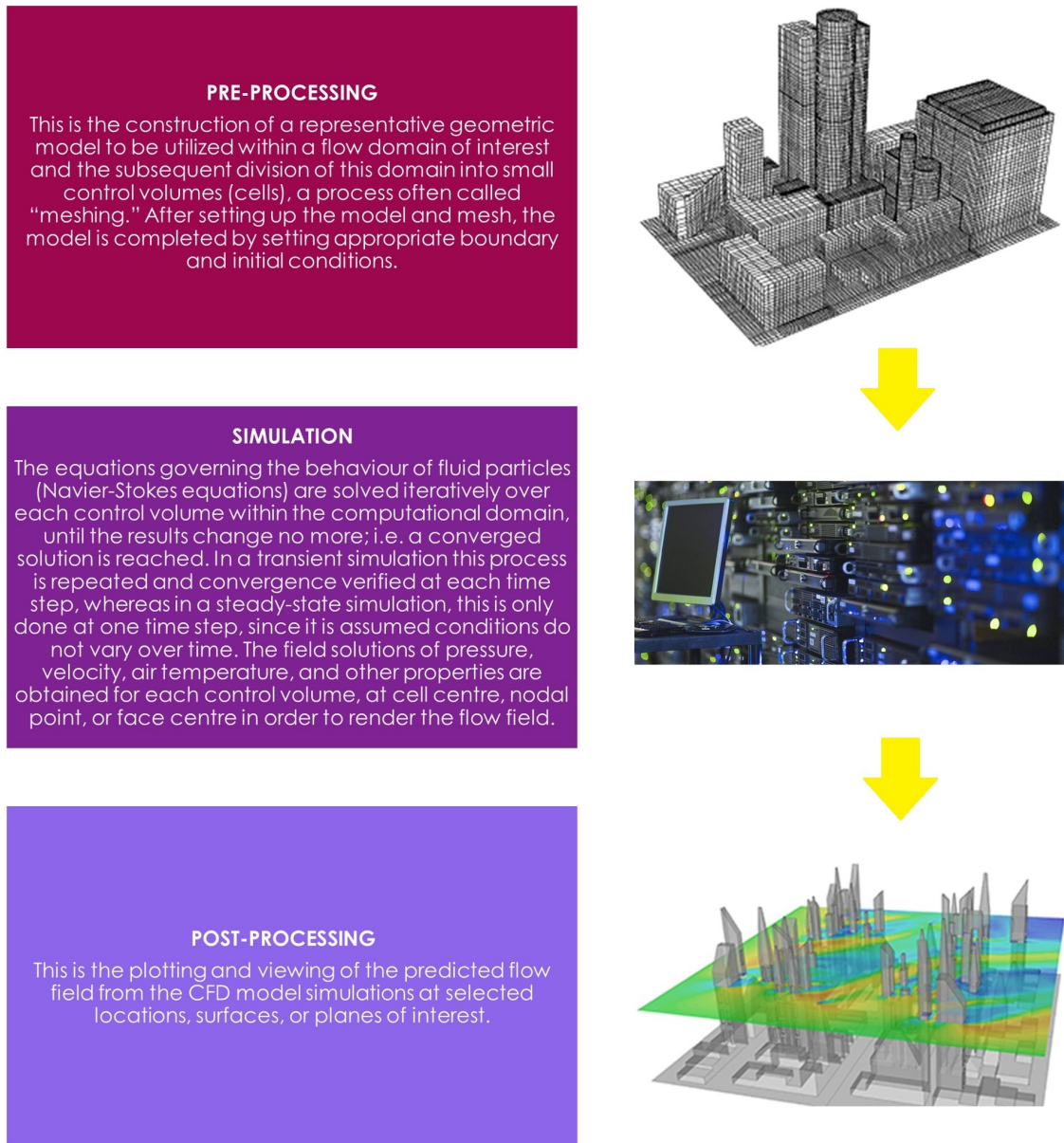

Figure 4.1: CFD Modelling Process Explanation

4.2 CFD SOFTWARE DETAILS

This report employs OpenFOAM Code, based on the concept of Reynolds-Averaged Navier-Stokes (RANS) formulations and the post-processing visualisation tool ParaView. OpenFOAM is a CFD software released and developed primarily by OpenCFD Ltd, since 2004. It has a large user base across most areas of engineering and science, from both commercial and academic organisations. OpenFOAM has an extensive range of features to solve anything from complex fluid flows involving chemical reactions, turbulence and heat transfer, to acoustics, solid mechanics and electromagnetics.

4.3 CFD MODEL DETAILS

4.3.1 FLOW ASSUMPTIONS & TURBULENCE MODELLING

In this study, the air flow is assumed to be incompressible, Newtonian, and statistically steady with temperature and gravity effects neglected. The flow is governed by the Reynolds-Averaged Navier–Stokes (RANS) formulation for mass and momentum where the turbulence is modeled using the $k-\omega$ SST turbulence model.

4.3.2 MODELED GEOMETRIES

The extent of the built area (e.g. buildings, structures or topography) that is represented in the numerical domain depends on the influence of the features on the region of interest. According to the Best Practice Guideline (COST Action 732), a building with height H (height of the tallest proposed building is $\approx 22\text{m}$) may have a minimal influence if its distance from the region of interest is greater than $6-10H$ (we considered 500m which is even larger than required).

The modelled layout and dimensions of the surrounding environment are outlined in the table below (Table 4.1).

	MODELLED CFD ENVIRONMENT DIMENSIONS		
	Width	Length	Height
Computational Domain	Approx.1200m	Approx.1000m	Approx.160m

Table 4.1: Modelled Environment Dimensions

A 3D view of the proposed development massing model in the domain is presented in Figure 4.2. Geometries used in this study include two parts:

- The massing model of the Proposed Part 8 Residential development, which is generated based drawings provided by on behalf of the NDFA and Dun Laoghaire County Council;
- The massing model of the building blocks within 500m from the development (colored in grey).



Figure 4.2: 3D View of the Massing Models of the Proposed Part 8 Residential development and Surrounding Building Blocks (colored in grey)

4.3.3 COMPUTATIONAL MESH

The computational mesh used in this report is created using OpenFOAM utilities blockMesh and snappyHexMesh. It is a hybrid mesh containing a structured background grid and an unstructured hexahedron-dominated mesh in the near-wall region. The largest cell has a depth of 5m, where the smallest has a depth of 0.15m. The total cell count is approx. 60 million. An isometric view of the geometry captured by the computational mesh is shown in Figure 4.3.

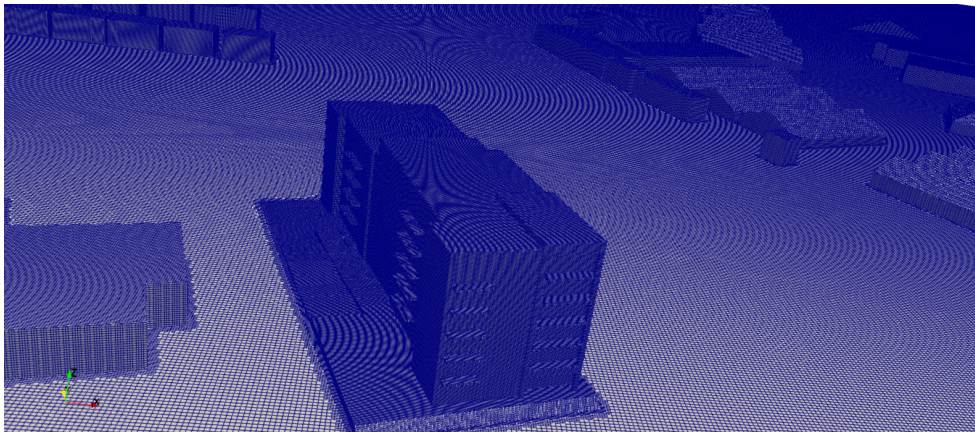

Figure 4.3: Computational Mesh of Proposed Part 8 Residential

4.3.4 BOUNDARY CONDITIONS

For each wind directions, an initial wind velocity was set based on logarithmic wind profile. Surfaces within the model were specified as having ‘no slip’ condition. This boundary

condition, ensures that flow moving parallel to a surface is brought to rest at the point where it meets the surface. All the other domain boundaries are set as "Open Boundaries".

The wind velocity data provided by the historical data collection and by the local data measuring are used in the formula below for the logarithmic wind profile to specify the wind velocity profile (wind velocity at different heights) to be applied within the CFD model:

$$u_{(z)} = \frac{u^*}{K} \cdot \ln\left(\frac{z+z_0}{z_0}\right) \quad (4.1)$$

where:

- $u_{(z)}$ = wind speed measured at the reference height z
- z = height to measure $u_{(z)}$
- z_0 = roughness length selected according to Eurocode
- u^* = friction velocity
- K = Karman constant

4.3.5 NUMERICAL CONFIGURATIONS

In this study, all simulations employ the SIMPLE algorithm to perform the pressure–velocity coupling (simpleFoam solver in OpenFOAM). All terms in the RANS equations are discretized using the nominally second-order cell-centred finite volume method, where gradient and Laplacian terms are discretized using Gaussian integration with linear interpolation. Convection/advection terms are discretized using a second-order accurate linear-upwind scheme.

4.3.6 PARALLEL CONFIGURATIONS

The computational mesh was decomposed using the SCOTCH algorithm. All simulations in this study are performed in parallel on an in-house HPC cluster. Key parameters of the CFD model used in this wind microclimate study are summarised in Table 4.2.

Table 4.2: Key parameters of the CFD model for each wind scenario

KEY PARAMETERS OF THE CFD MODEL	
Air Density (ρ)	1.2 kg/m ³
Turbulence Model	k- ω SST Model
Cell Size	Approx. 0.15 m at the development Approx. 0.3 m in the surroundings 5 m elsewhere
Total Cell Count	Approx. 60 million

5. LOCAL WIND CLIMATE

5.1 THE EXISTING RECEIVING ENVIRONMENT

In this chapter, wind impact has been assessed on the existing receiving environment considered the existing buildings and the topography of the site prior of the construction of the proposed development. A statistical analysis of 15 years historical weather wind data has been carried out to assess the most critical wind speeds, directions and frequency of occurrence of the same. The aim of this assessment has been to identify the wind microclimate of the area that may cause critical conditions for pedestrians comfort criteria.

5.1.1 SITE LOCATION AND SURROUNDING AREA

The Proposed Part 8 Residential Development will be situated in Balally, Blackthorn Drive, Sandyford, Dublin 16. The Existing Environment site is shown in Figure 5.1. The area considered for the existing environment and proposed development assessment comprises an Approx. 0.7 km² area around the Proposed Part 8 Residential Development as represented in Figure 5.2.

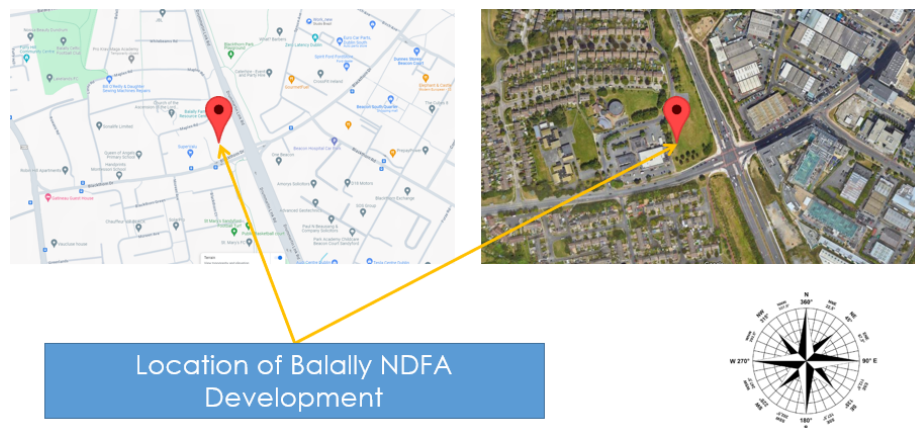

Figure 5.1: Part 8 Residential Development Site Location and Existing Environment

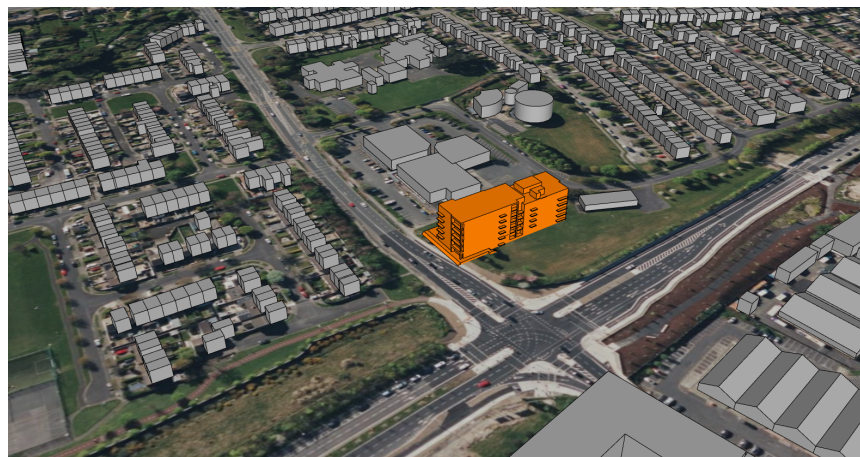

Figure 5.2: Extents of Analysed Existing Environment Around the Proposed Part 8 Residential Development

5.1.2 TOPOGRAPHY AND BUILT IN ENVIRONMENT

Figure 5.3 shows an aerial photograph of the terrain surrounding the construction site at the Proposed Part 8 Residential Development. The Proposed Part 8 Residential Site is located in Blackthorn Drive. Therefore, the area surrounding the site can be characterised as urban environment with family houses in the west and mix of industrial and residential complexes to the east.

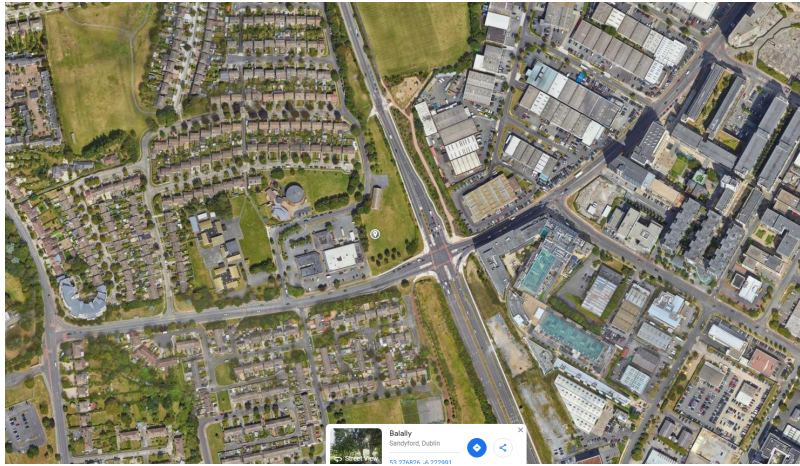

Figure 5.3: Built-in Environment Around Construction Site at the Proposed Part 8 Residential Development

5.2 LOCAL WIND CONDITIONS

This analysis considers the whole development being exposed to the typical wind condition of the site. The building is oriented as shown in the previous sections. The wind profile is built using the annual average of meteorology data collected at Dublin Airport Weather Station. Figure 5.4 shows on the map, the position of the Proposed Part 8 Residential Development and the position of Dublin Airport.

Regarding the transferability of the available wind climate data, the following considerations have been made:

- *Terrain:* The meteorological station is located on the flat open terrain of the airport, whereas the development site is in an urban area with built-in structures including buildings of around 10 m height in average (warehouses and houses).
- *Wind Directions:* The landscape around the development site can in principle be characterized as flat terrain. Isolated elevations in the near area of the development should have no influence on the wind speed and wind directions. With respect to the general wind climate no significant influence is expected. Based on the above considerations it can be concluded that the data from the meteorological station at Dublin Airport are applicable for the desktop assessment of the wind comfort at the development site.

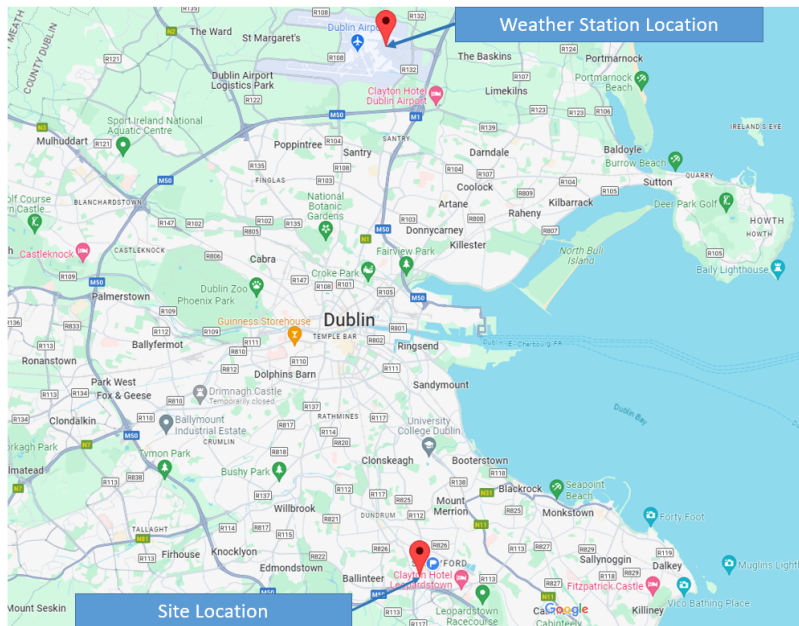

Figure 5.4: Map showing the position of the Proposed Part 8 Residential Development and Dublin Airport

The assessment of the wind comfort conditions at the new development will be based on a discrete set of wind data throughout a year (annual wind statistic) provided by Meteoblue for Dublin Airport meteorological wind station. In this study, a 12-discrete set of wind directions is utilized to evaluate the probability of exceedance at any given threshold speed. A Weibull probability distribution is employed to transform the provided wind data into a continuous distribution for each wind direction. From the Weibull distribution function, the probability (P) for each wind direction can be obtained by:

$$P = e^{-\left(\frac{U}{c}\right)^k}$$

Where c is the scale parameter and k is the shape parameter for a wind speed U.

Statistical analysis of the number of hours and magnitudes of wind is performed in order to indicate the pedestrian comfort and distress analysis as per Lawson Criteria. Each of the wind directions were interpolated to calculate the probability that a velocity threshold will be exceeded. Based on the criterion of occurrence frequency, if the proposed site is exposed to a wind from a specific direction for more than 5 percent of the time, then the microclimate analysis should consider the impact of this wind (accounting for its direction and most frequent speed) on the local microclimate. However, to get complete picture we ran simulations for wind from 12 distinct directions equally spaced around the development (every 30°).

As stated above, the local wind climate is determined from historical meteorological data recorded at Dublin Airport meteorological wind station. The data set analyzed for this assessment is based on the meteorological data associated with the maximum daily wind speeds recorded over a 15-year period between 2008 and 2023 at a weather station at the airport, which is located 10m above ground. Figure 5.5 shows the wind speed record during the latest 5 years.

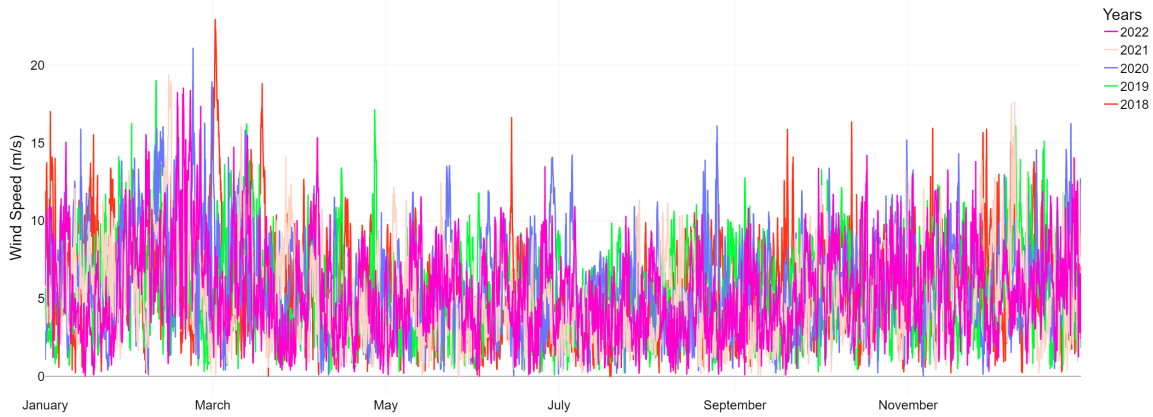

Figure 5.5: Local Wind Conditions - Wind Speed - 2018-2022

Figure 5.6 displays a wind speed diagram for Dublin, illustrating the number of days per month when the wind attains specific speeds. It is evident from this figure that strong winds are more prevalent during the winter season (December, January, and February) and the start of spring season (March) compared to other seasons.

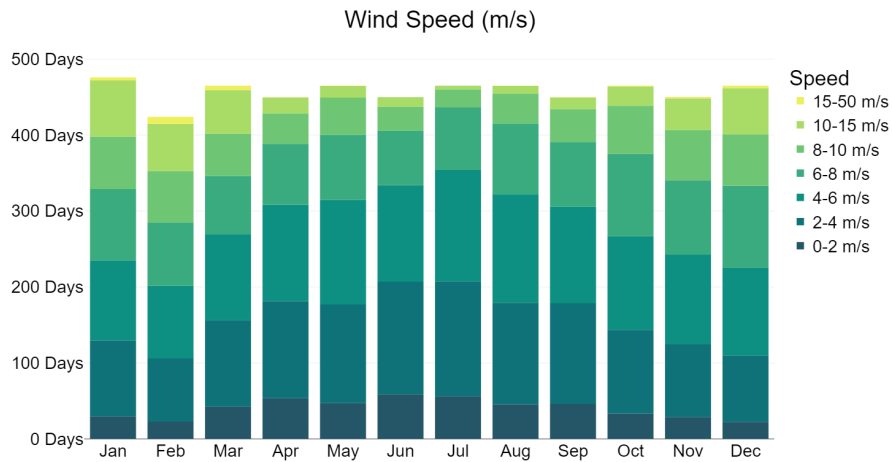

Figure 5.6: Dublin Wind Speed Diagram

Figure 5.7 displays the wind rose for the Proposed Part 8 Residential Development, revealing the percentage of wind coming from different directions over a 15-year period. Detailed percentages for each direction are outlined in Table 5.1. As depicted in Figure 5.7 and highlighted in Table 5.1, the highest probability of wind occurrence lies in the wind blowing from 240° to 300° with 270° being most prevalent. This finding indicates that west winds contribute significantly to the probability of discomfort exceedance. In addition, seasonal changes were analysed in order to indicate the prevailing wind directions (Fig 5.8).

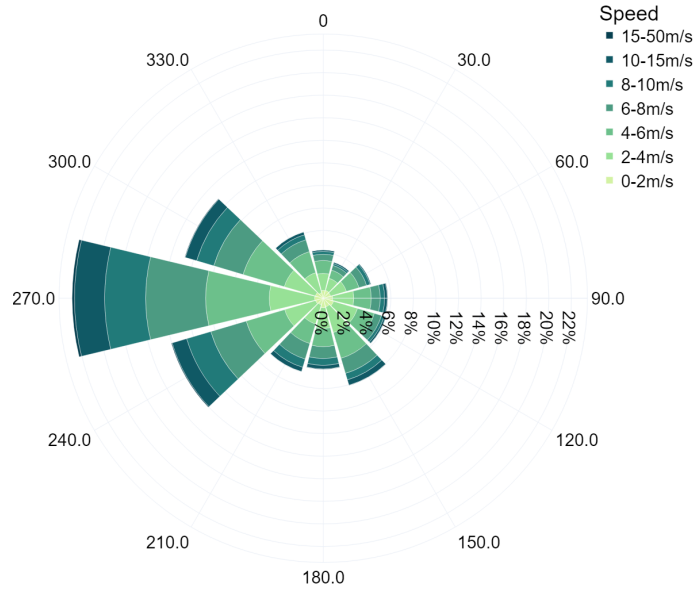

Figure 5.7: Dublin Wind Rose

Table 5.1: A detailed table includes wind occurrences, wind patterns, and roughness lengths for different wind directions.

Wind Direction	Scale Parameter	Shape Parameter	Roughness Length (z_0)	Frequency
270.00°	1.80	6.11	0.30	22.22%
240.00°	2.07	6.55	0.30	13.98%
300.00°	1.66	5.18	0.30	12.83%
150.00°	1.35	3.88	0.30	8.10%
210.00°	2.05	6.02	0.30	6.75%
180.00°	1.49	4.62	0.30	6.33%
330.00°	1.60	4.38	0.30	6.14%
120.00°	0.92	1.70	0.30	5.86%
90.00°	1.15	3.08	0.30	5.74%
60.00°	1.82	4.80	0.30	4.42%
0.00°	1.42	3.81	0.30	4.28%
30.00°	1.22	3.33	0.30	3.34%

In addition to the annual statistical analysis of wind occurrences (Figure 5.7), a detailed examination has been conducted to comprehend the wind conditions during each season. As illustrated in Figure 5.8, the wind patterns in spring closely resemble those in summer, with a higher percentage of winds coming from the east and north-east compared to the same direction in summer. Although in autumn the wind pattern is similar to winter, during winter, the winds occur more frequently and are stronger. In general, the predominant

winds come from the west at higher speeds compared to other wind directions throughout all seasons.

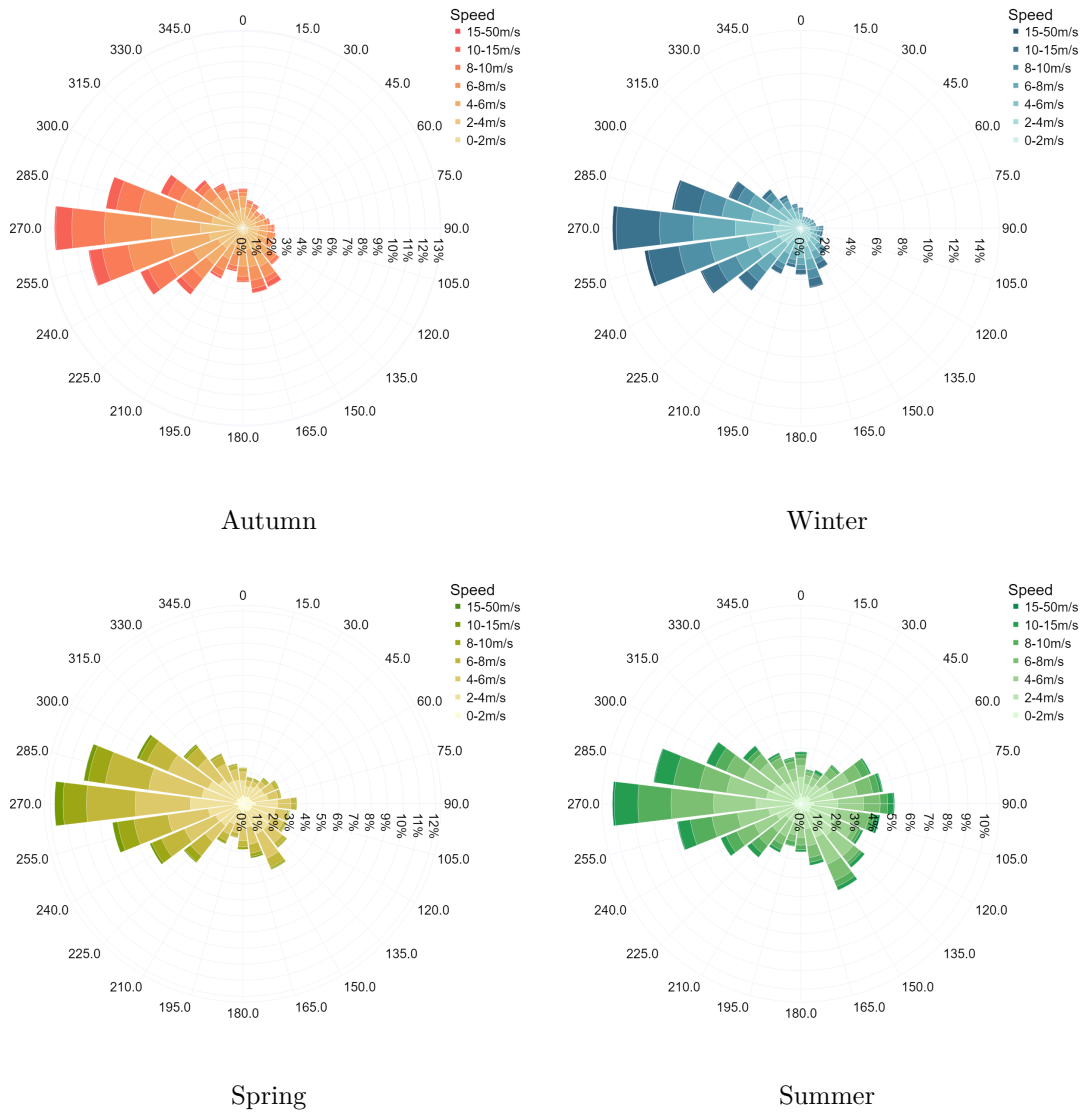

Figure 5.8: Wind speeds and wind directions at different seasons

6. CHARACTERISTICS OF THE PROPOSED DEVELOPMENT

6.1 DESCRIPTION OF THE PROPOSED DEVELOPMENT

The proposed development is located in the townland of Balally, on Blackthorn Drive, Sandyford, Dublin 16. The site is bounded by Cedar Road to the north, Balally Shopping Centre to the west, Blackthorn Drive to the south, and open space to the east. The proposed development includes:

- i. 62 no. apartment units in a 5-6 storey building over undercroft area, including 31 no. one bed units; 21 no. two bed units; and 10 no. three bed units;
- ii. 1 no. crèche facility of 297sqm with associated external play area at upper ground level.
- iii. Energy Centre at sixth floor level and an external plant area set back at fifth floor roof level.
- iv. Undercroft area at lower ground level comprising (a) 1 no. ESB substation (b) car and bicycle parking; (c) bin storage; (d) bulk storage area; and (e) supporting mechanical, electrical and water infrastructure.
- v. Landscaping works including provision of (a) communal open space; (b) new pedestrian and cycle connections linking Blackthorn Dive with Cedar Road; and (c) public realm area fronting onto Blackthorn Drive.
- vi. All associated site development works including (a) vehicular access off Cedar Road; (b) pedestrian and cycle access off Blackthorn Drive; (c) public lighting; (d) varied site boundary treatment; and (e) temporary construction signage.

The proposal has undergone Appropriate Assessment Screening under the Habitats Directive (92/43/EEC), and the relevant provisions of the Planning and Development Act 2000, as amended, and the Planning and Development Regulations 2001, as amended, and the European Communities (Bird and Natural Habitats) Regulations 2011 – 2015. Dún Laoghaire-Rathdown County Council has determined that the proposed development individually or in-combination with other plans or projects would not be likely to have a significant effect on a European site and an Appropriate Assessment (AA) is not required.

Figure 6.1 shows a view of the proposed development (coloured) and existing surround buildings (colored in grey).

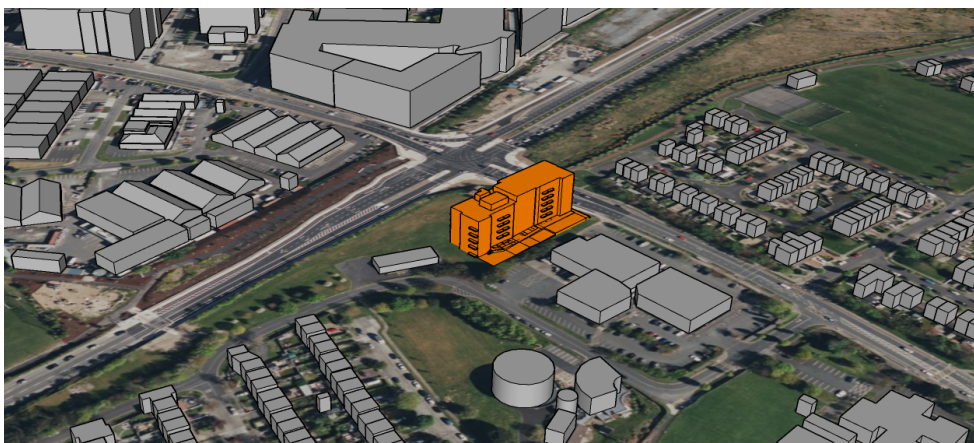

Figure 6.1: Proposed Part 8 Residential Development (coloured)

6.2 POTENTIAL RECEPTORS

Potential receptors for the wind assessment are all pedestrian circulation routes, building entrances and leisure open areas within the site and in neighboring adjacent areas. The pedestrian level is considered at 1.5m above ground. Figure 6.2 shows the pedestrian activity area on the ground and the walkways around the development. These areas are considered as sensitive potential receptors for the wind microclimate.

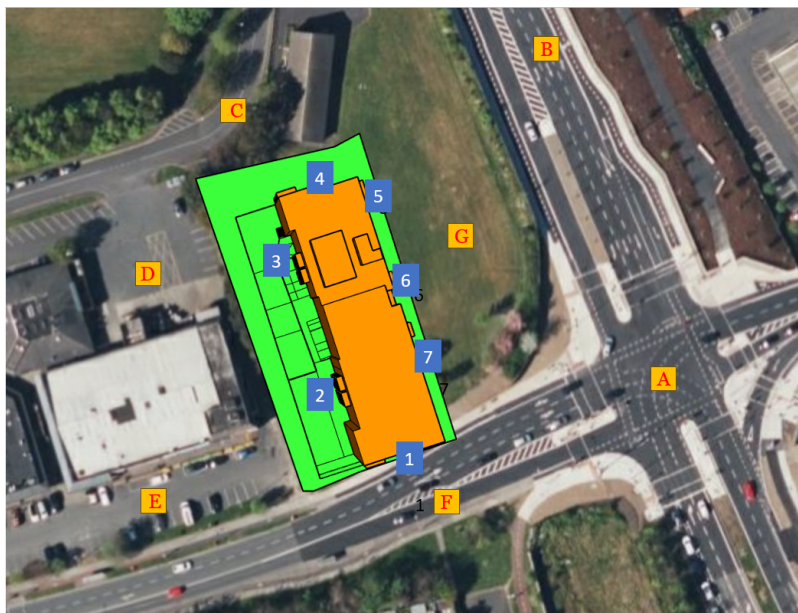

Figure 6.2: Potential Sensitive Receptors on the Ground - Pedestrian Activities Area

Table 6.1: List of the receptors.

On-Site Potential Receptors ID	Description	Off-Site Potential Receptors ID	Description
1.	South Entrance.	A.	Crossroad of Blackthorn Dr and Drummartin Link Rd.
2.	Garden and playground.	B.	Drummartin Link Rd.
3.	Courtyard.	C.	Maples Rd.
4.	Garage Entrance.	D.	Parking lot and supply depo.
5.	Cycle and Pedestrian Connection.	E.	Shop entrances.
6.	Cycle and Pedestrian Connection.	F.	Blackthorn Dr.
7.	Cycle and Pedestrian Connection.	G.	Lawn.

7. BASELINE WIND MICROCLIMATE

7.1 BASELINE SCENARIO

The wind microclimate of the baseline scenario is defined by the wind patterns that develop on the site and its surroundings (existing buildings and topography) under the local wind conditions relevant for the assessment of the Pedestrian Comfort and Distress.

In this scenario the assessment has considered the impact of wind on the existing area. Results of wind microclimate at pedestrian level (1.5m height - flow speeds) are collected throughout the modelled site. These flow velocities identify if locally, wind speeds at pedestrian level are accelerated or decelerated in relation to the undisturbed reference wind speed due to the presence of the existing baseline environment.

The impact of these speeds are then combined with their specific frequency of occurrence and presented in the maps that show the area of comfort and distress in accordance with Lawson Criteria, these maps are produced at pedestrian level on the ground and identify the suitability of each areas to its prescribed level of usage and activity.

7.1.1 WIND SPEEDS - PEDESTRIAN LEVEL

Results of wind speeds and their circulations at pedestrian level of 1.5m above the development ground are presented in Figures 7.1 to 7.12 in order to assess wind flows at ground floor level of the Proposed Part 8 Residential Development.

Wind flow speeds are shown to be within tenable conditions. The site experiences high wind velocity when the wind originates from the North or South-East. This high velocity is notable at wind angles of 0° , 120° and 150° .

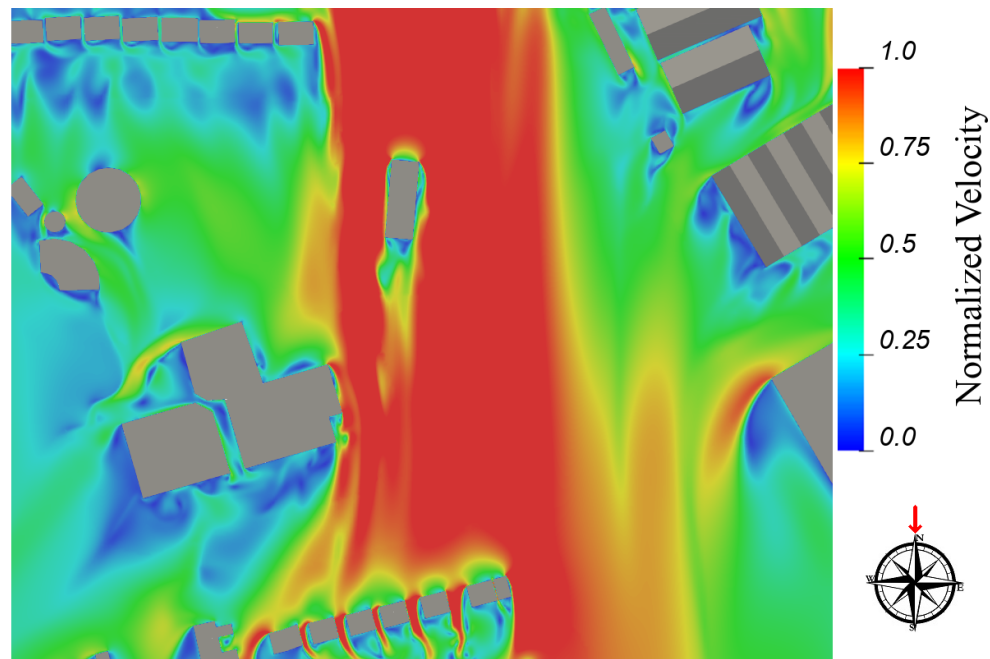

Figure 7.1: Ground Floor Level - Flow Velocity Results at $Z=1.5\text{m}$ above the ground - Wind Direction: 0°

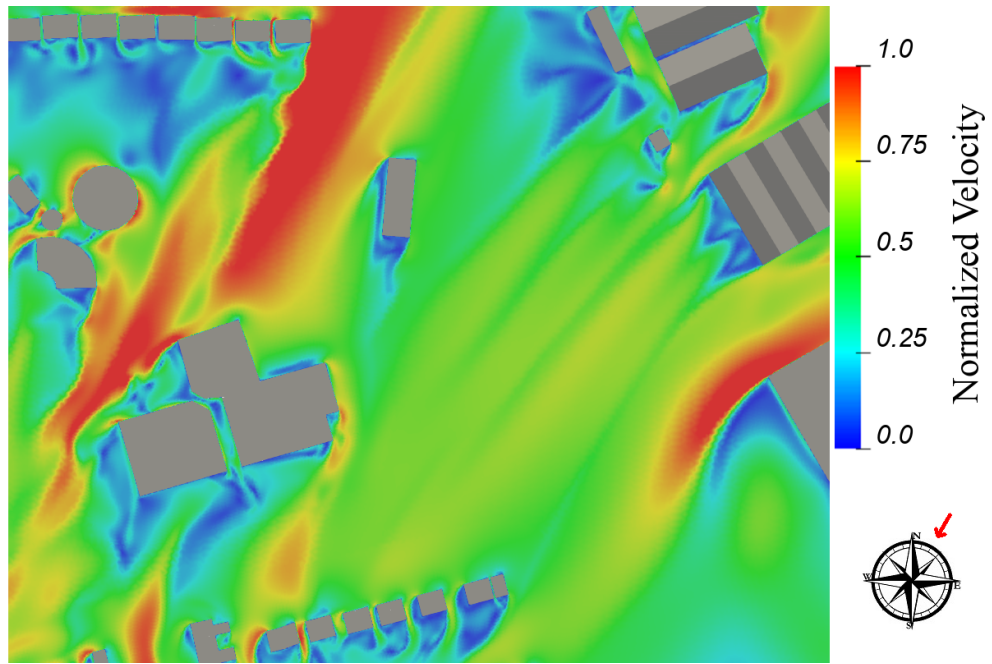

Figure 7.2: Ground Floor Level - Flow Velocity Results at Z=1.5m above the ground - Wind Direction: 30°

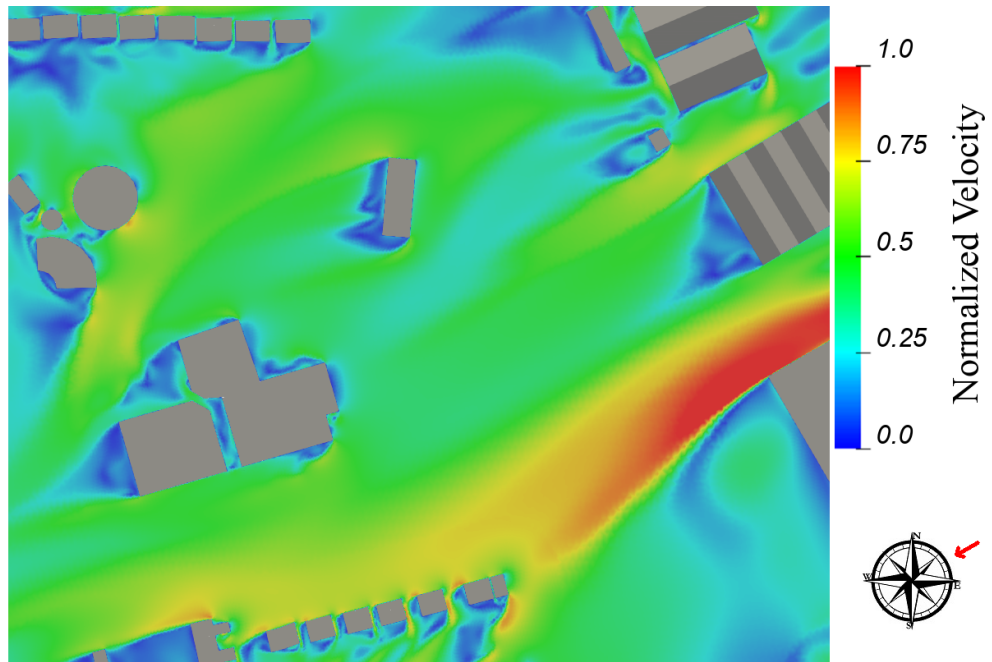

Figure 7.3: Ground Floor Level - Flow Velocity Results at Z=1.5m above the ground - Wind Direction: 60°

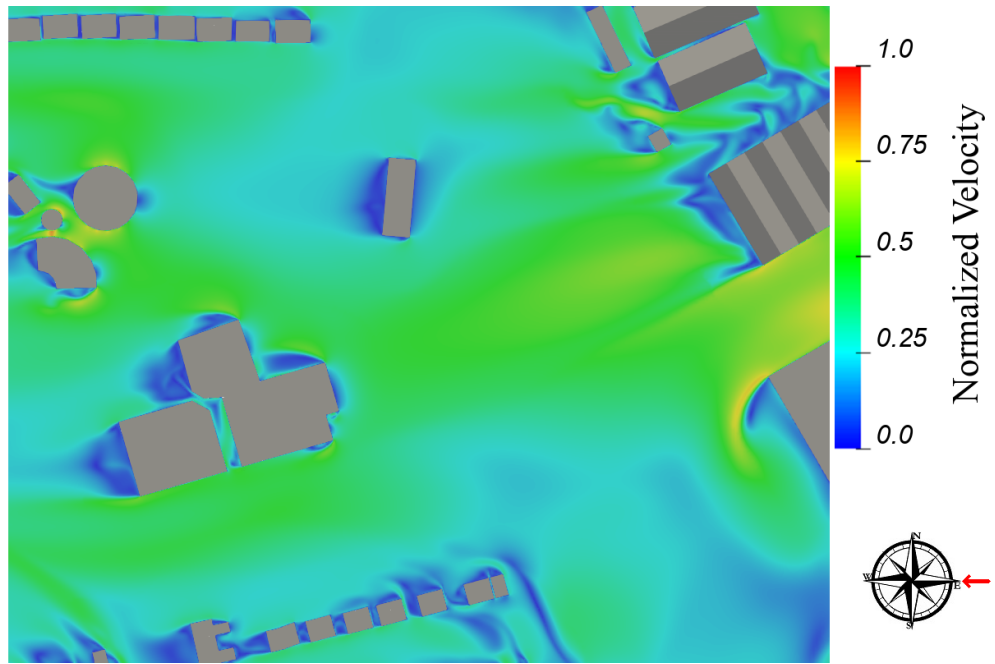

Figure 7.4: Ground Floor Level - Flow Velocity Results at Z=1.5m above the ground - Wind Direction: 90°

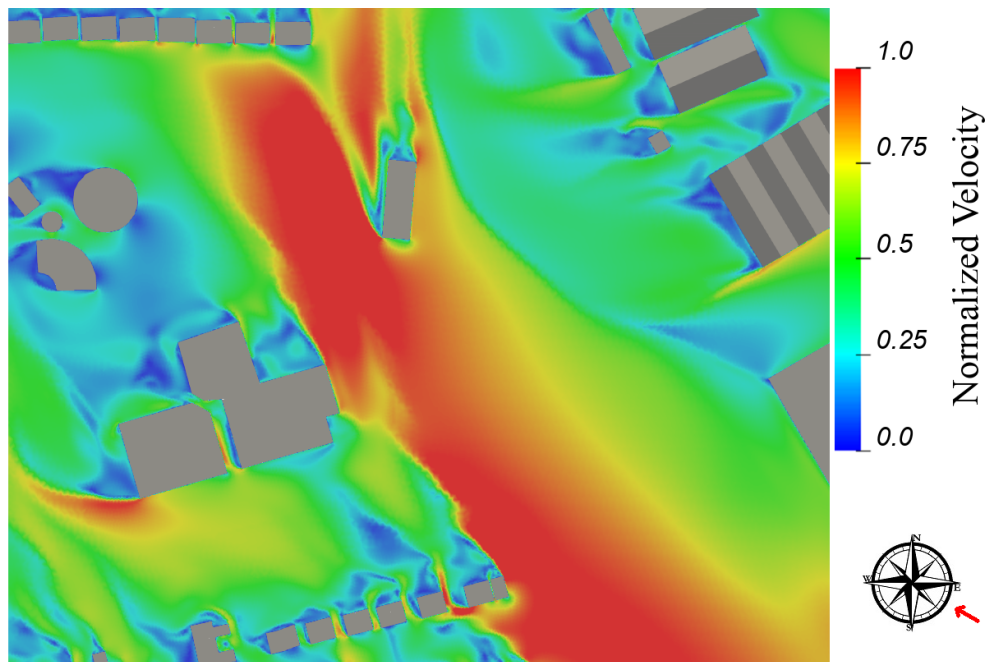

Figure 7.5: Ground Floor Level - Flow Velocity Results at Z=1.5m above the ground - Wind Direction: 120°

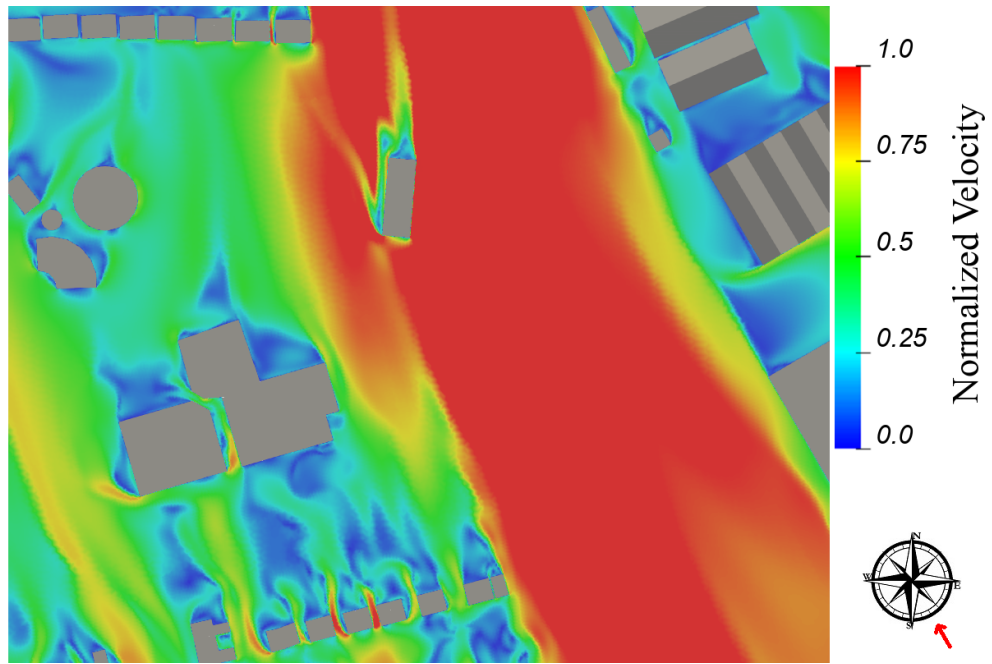

Figure 7.6: Ground Floor Level - Flow Velocity Results at Z=1.5m above the ground - Wind Direction: 150°

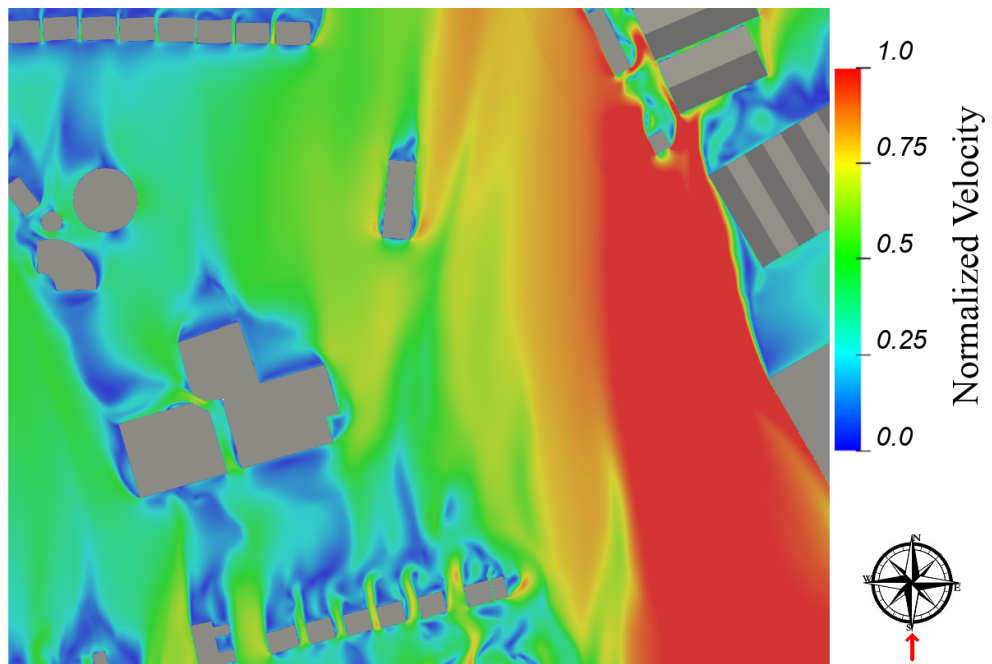

Figure 7.7: Ground Floor Level - Flow Velocity Results at Z=1.5m above the ground - Wind Direction: 180°

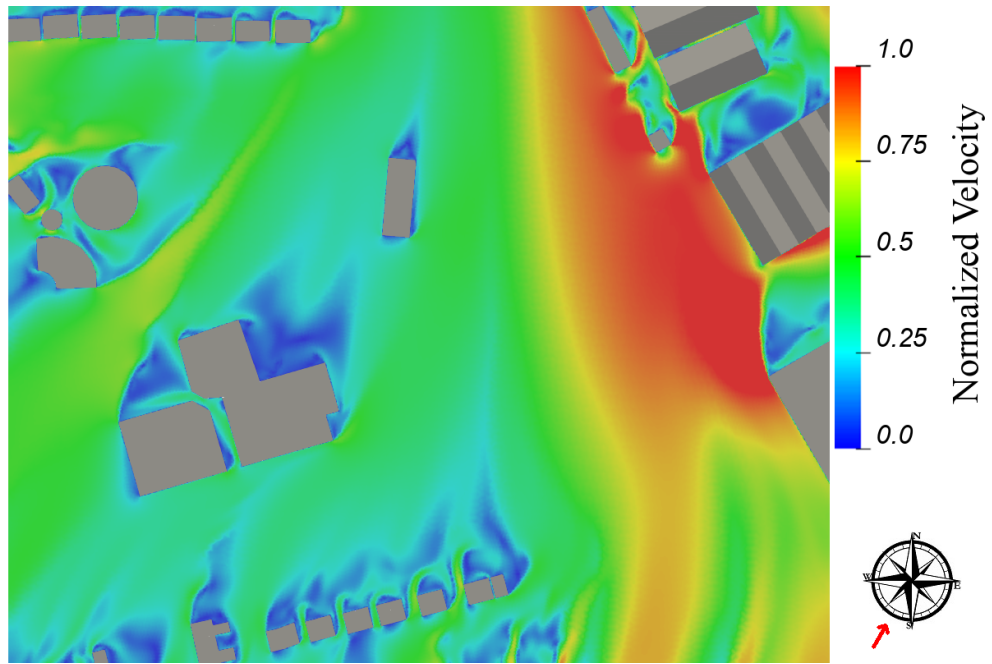

Figure 7.8: Ground Floor Level - Flow Velocity Results at Z=1.5m above the ground - Wind Direction: 210°

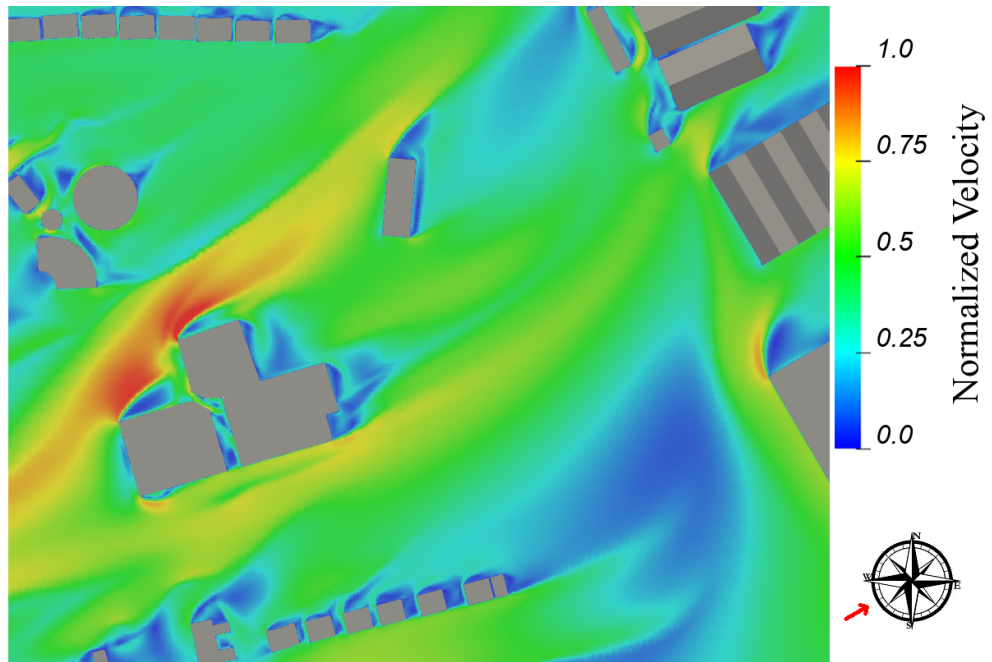

Figure 7.9: Ground Floor Level - Flow Velocity Results at Z=1.5m above the ground - Wind Direction: 240°

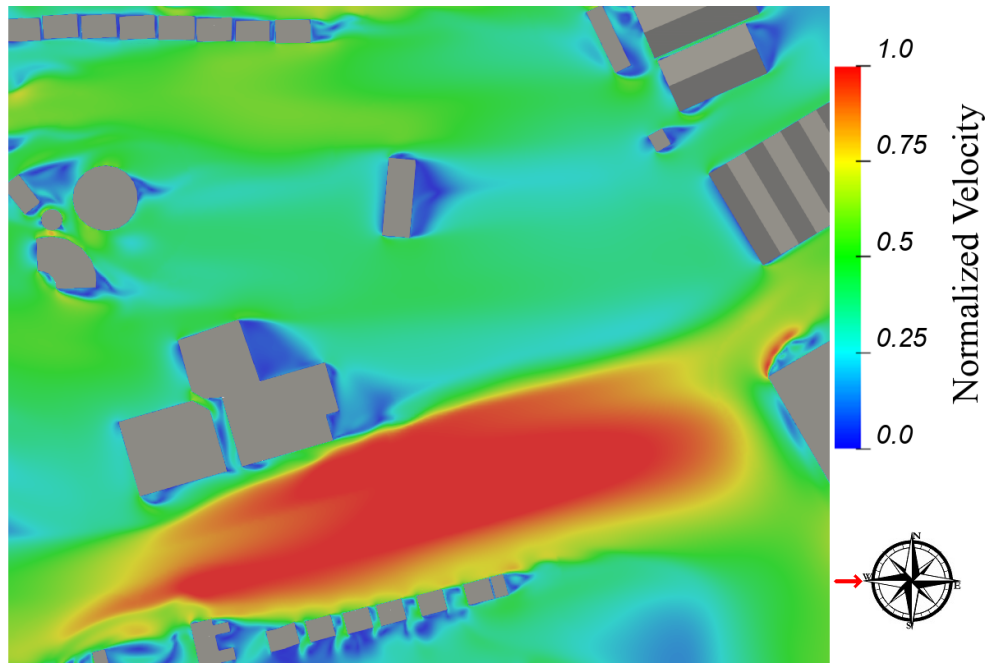

Figure 7.10: Ground Floor Level - Flow Velocity Results at $Z=1.5\text{m}$ above the ground - Wind Direction: 270°

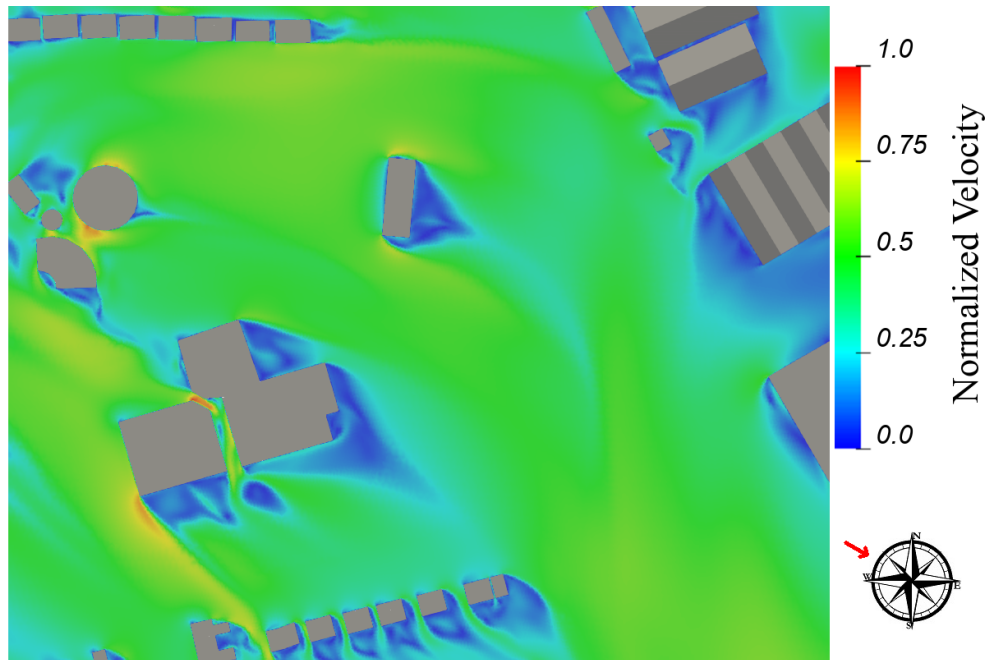

Figure 7.11: Ground Floor Level - Flow Velocity Results at $Z=1.5\text{m}$ above the ground - Wind Direction: 300°

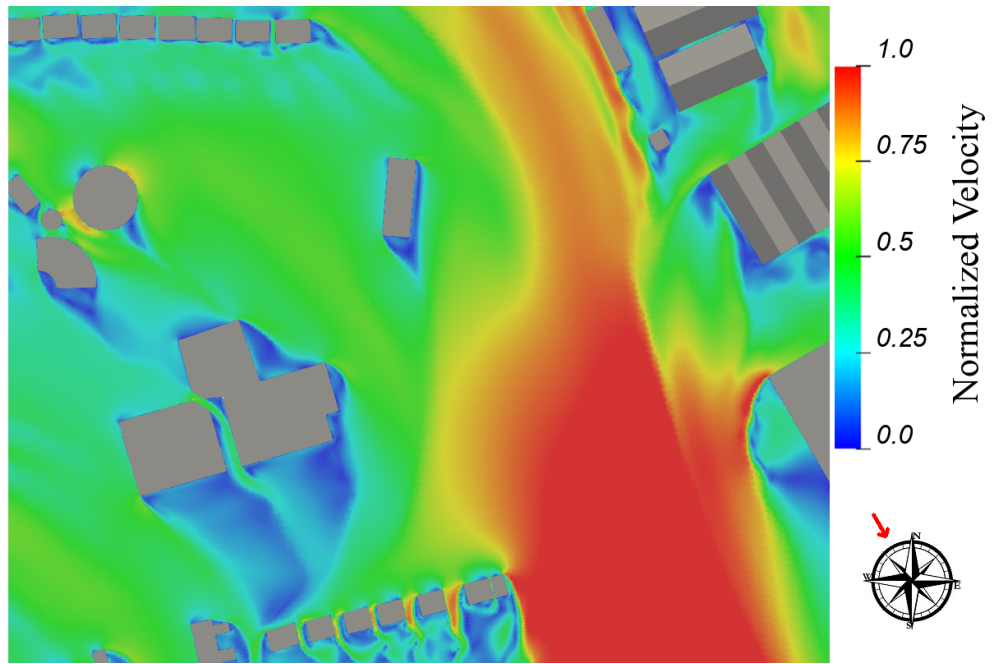

Figure 7.12: Ground Floor Level - Flow Velocity Results at $Z=1.5\text{m}$ above the ground - Wind Direction: 330°

7.1.2 BASELINE WIND MICROCLIMATE - LAWSON CRITERIA

The wind flow results obtained simulating the different direction and wind speeds, are combined with wind frequencies of occurrence to obtain comfort ratings at pedestrian level in all areas included within the model. The comparison of comfort ratings with intended pedestrian activities is shown in the Lawson Comfort and Distress Map that follows. The comfort/distress conditions are presented using a colour coded diagram formulated in accordance with the Lawson Criteria.

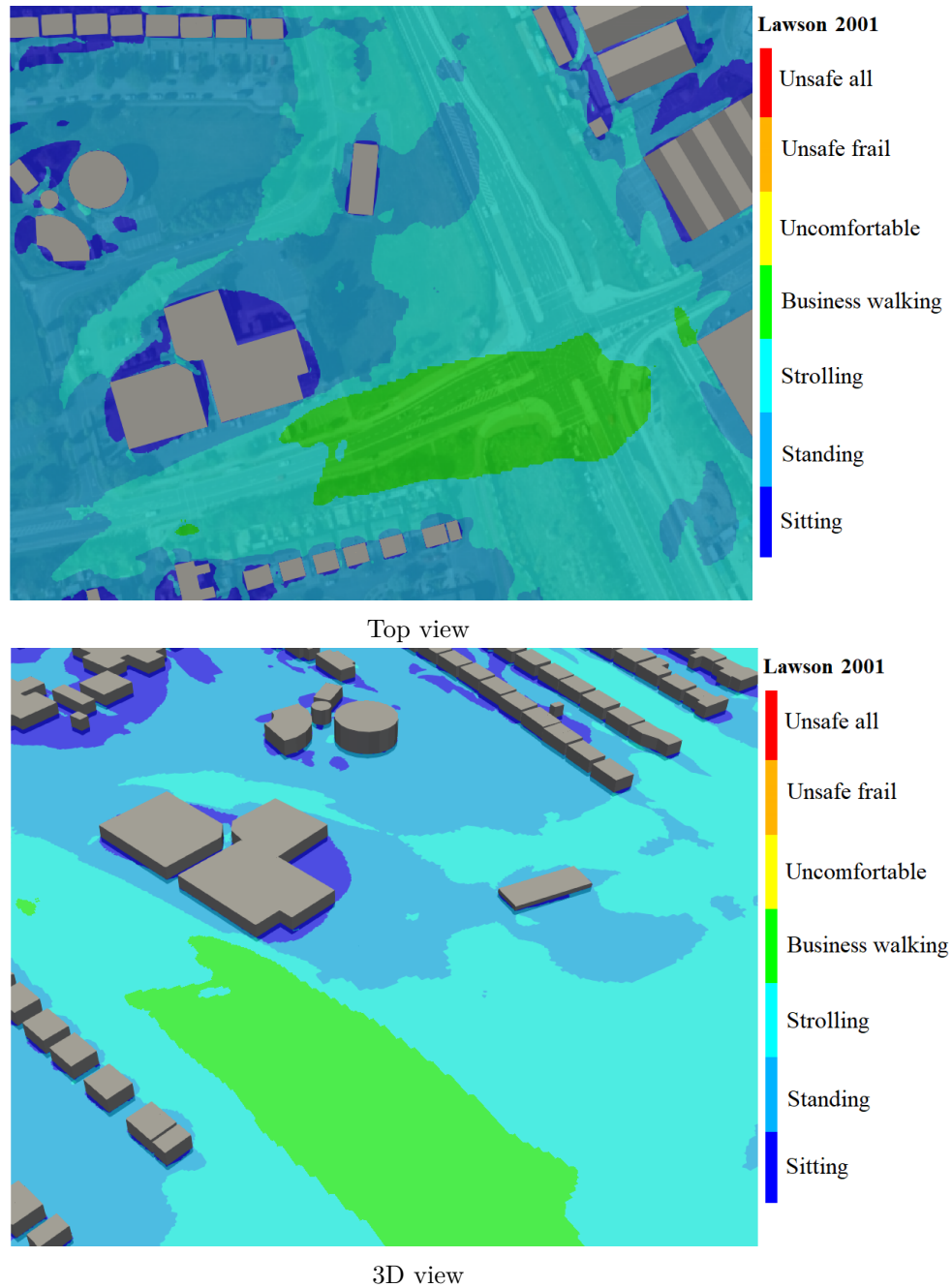

Figure 7.13: Ground Floor - Lawson Discomfort Map - Baseline scenario

From the simulation results the following observations are pointed out:

- The assessment of the baseline scenario has shown that no area is unsafe and no conditions of distress are created in the existing environment under the local wind climate.
- The site is usable for Standing/Strolling, the roads in the surrounding are usable for their intended scope.

8. IMPACT OF THE PROPOSED DEVELOPMENT

This section assessed the potential impact of the proposed development on the already existing environment, and the suitability of the proposed development to create and maintain a suitable and comfortable environment for different pedestrian activities.

8.1 CONSTRUCTION PHASE

As the finalization of the development proceeds, the wind setting at the site would progressively conform to those of the completed development. Due to the fact that windier conditions are acceptable within a construction area (not accessible to the public), and the proposed development would not be the reason for critical wind conditions on-Site (and are slightly calmer when the development is in site), the impacts evaluated on-Site are considered to be insignificant. Thus, the predicted impacts during construction phase are identified as not significant or negligible.

In summary, as construction of the Proposed Part 8 Residential Development progresses, the wind conditions at the site would gradually adjust to those of the completed development. During the construction phase, predicted impacts are classified as negligible.

8.2 OPERATIONAL PHASE

This section shows CFD results of wind microclimate assessment carried out considering the "Operational Phase" of the Proposed Part 8 Residential Development. In this case the assessment has considered the impact of wind on the existing area including the Proposed Part 8 Residential Development. Wind simulations have been carried out on all the various directions for which the development could show critical areas in terms of pedestrian comfort and safety.

Results of wind microclimate at pedestrian level (1.5m height - flow speeds) are collected throughout the modelled site (potential receptors). These flow velocities identify if locally, wind speeds at pedestrian-level are accelerated or decelerated in relation to the undisturbed reference wind speed due to the presence of the existing baseline environment.

The impact of these speeds are then combined with their specific frequency of occurrence and presented in the maps that show the area of comfort and distress in accordance with Lawson Criteria, these maps are produced at pedestrian level on the ground or on the courtyards, and identify the suitability of each areas to its prescribed level of usage and activity.

8.2.1 WIND SPEEDS - PEDESTRIAN LEVEL

Results of wind speeds and their circulations at pedestrian level of 1.5m above the potential receptors are presented in Figures 8.1 to 8.12 in order to assess wind flows at the ground floor level of the Proposed Part 8 Residential Development.

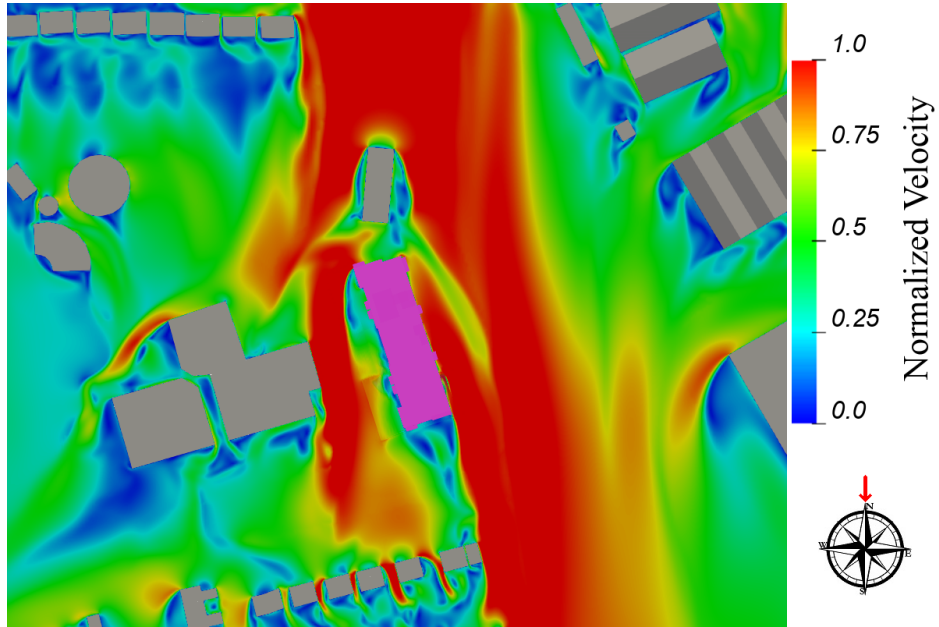

Figure 8.1: Flow Velocity Results at 1.5m above the ground - Wind Direction: 0°

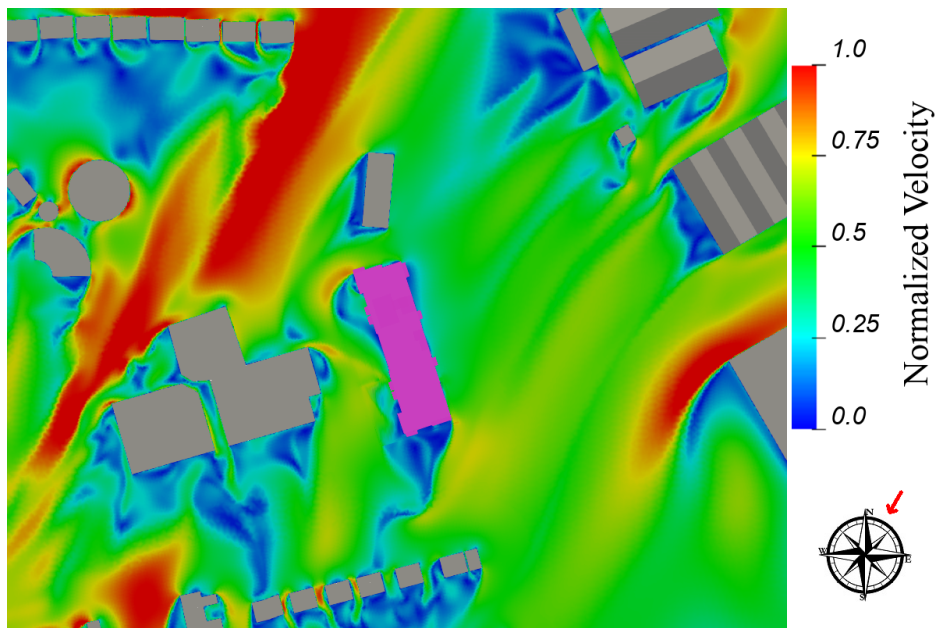

Figure 8.2: Flow Velocity Results at 1.5m above the ground - Wind Direction: 30°

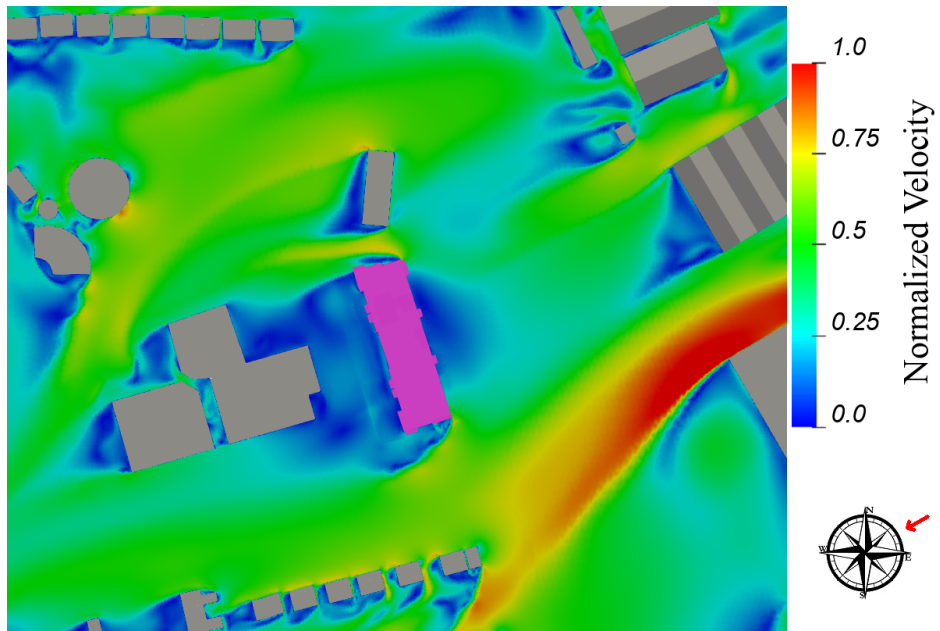

Figure 8.3: Flow Velocity Results at 1.5m above the ground - Wind Direction: 60°

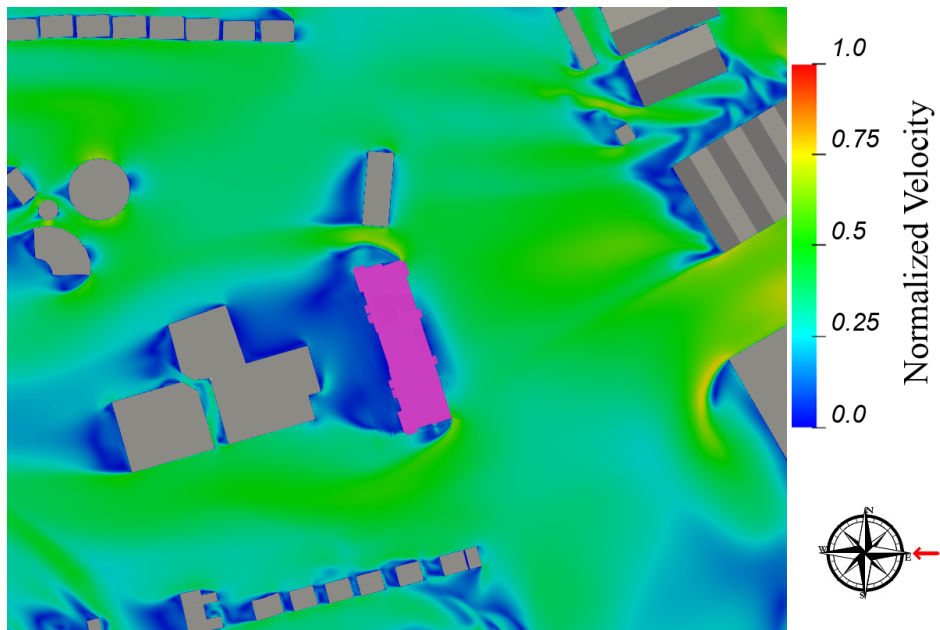

Figure 8.4: Flow Velocity Results at 1.5m above the ground - Wind Direction: 90°

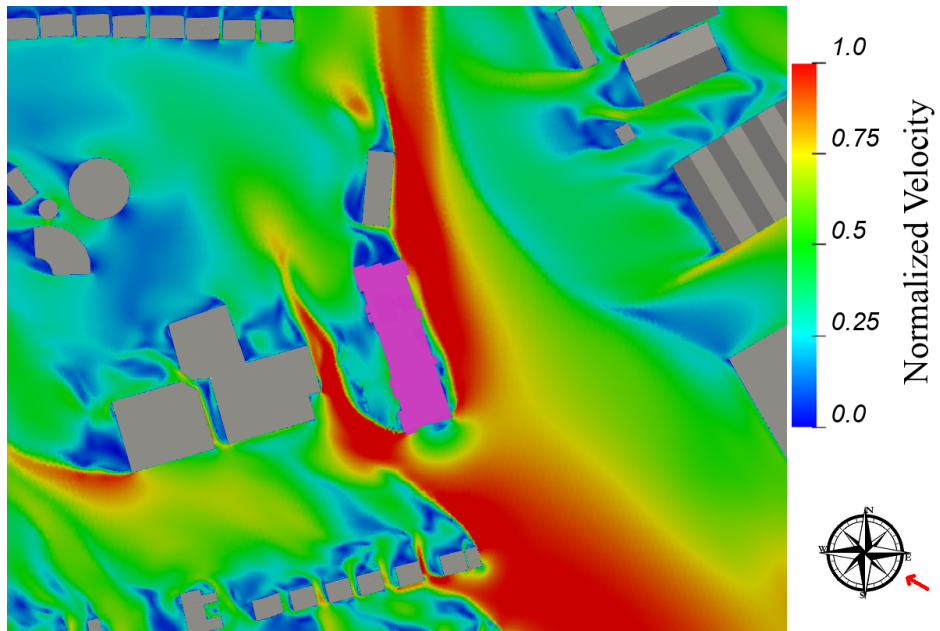

Figure 8.5: Flow Velocity Results at 1.5m above the ground - Wind Direction: 120°

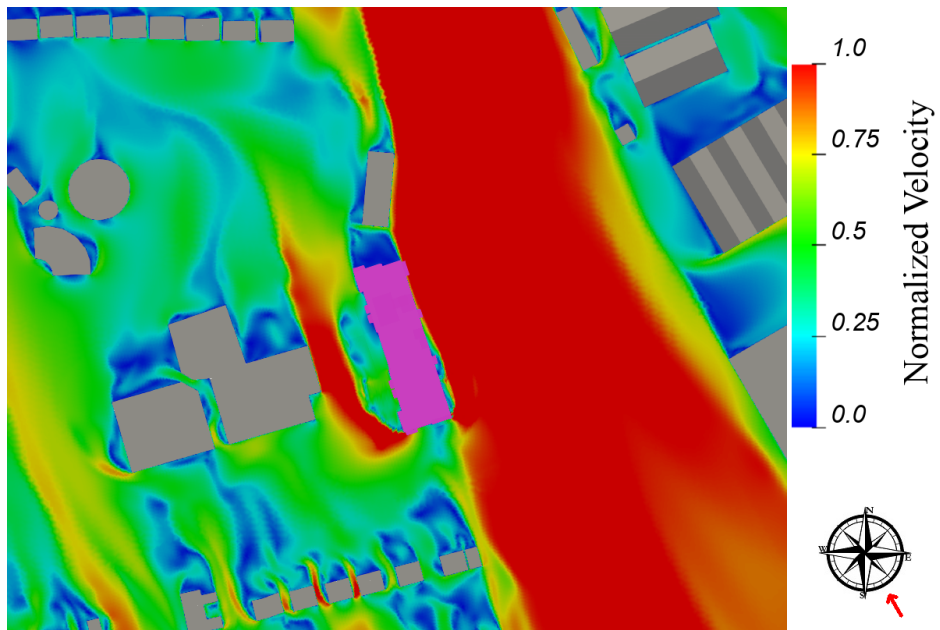

Figure 8.6: Flow Velocity Results at 1.5m above the ground - Wind Direction: 150°

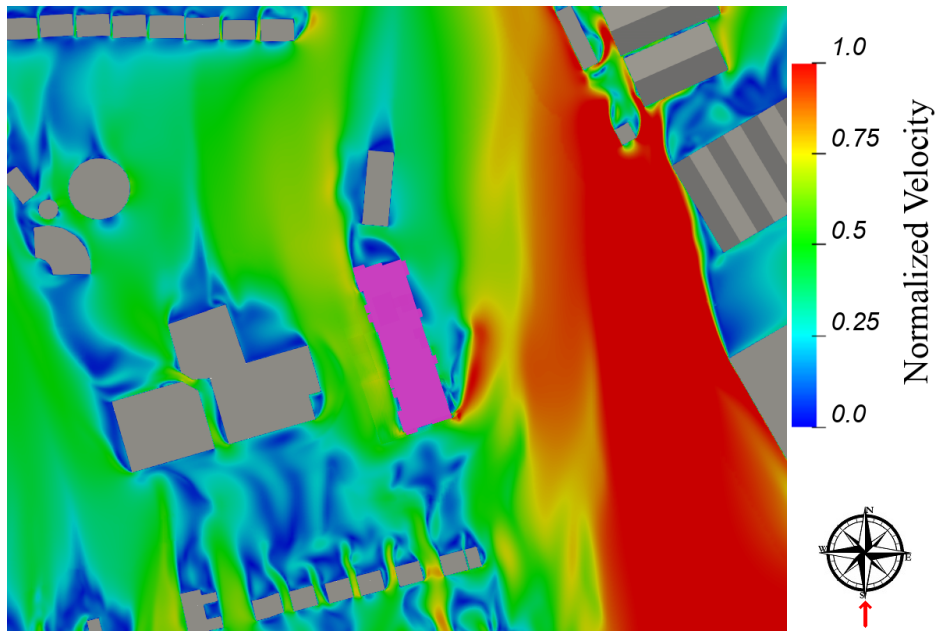

Figure 8.7: Flow Velocity Results at 1.5m above the ground - Wind Direction: 180°

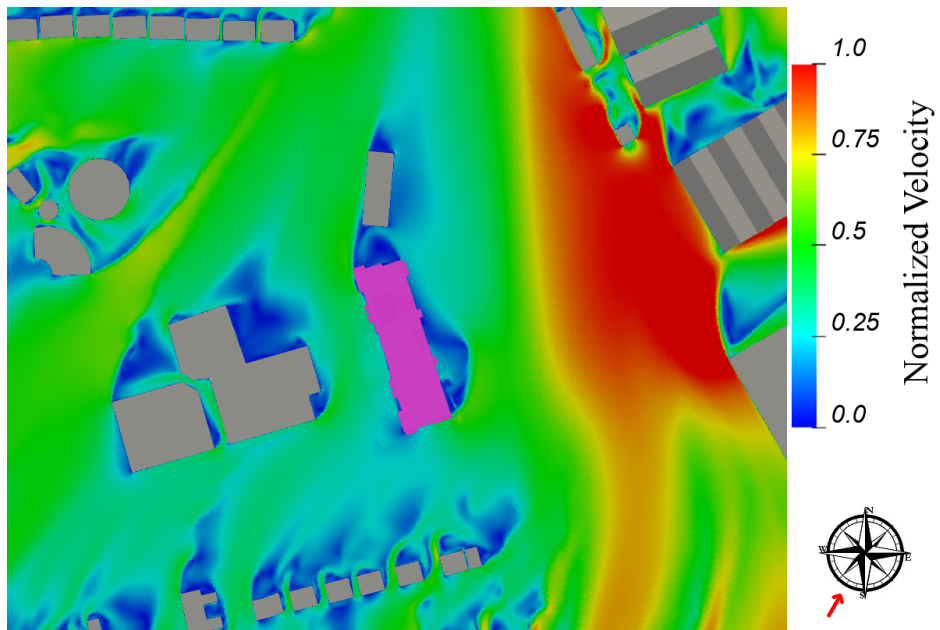

Figure 8.8: Flow Velocity Results at 1.5m above the ground - Wind Direction: 210°

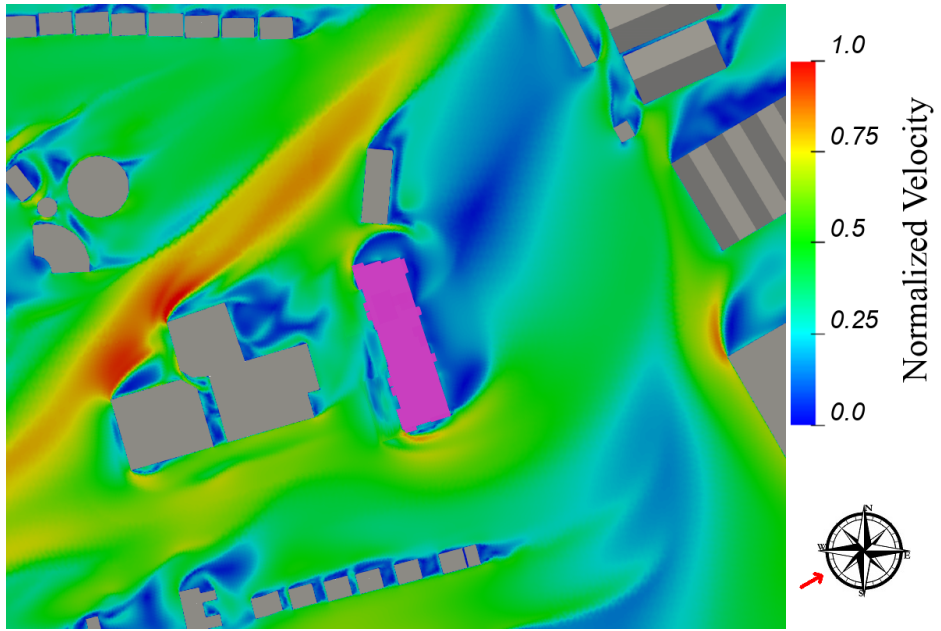

Figure 8.9: Flow Velocity Results at 1.5m above the ground - Wind Direction: 240°

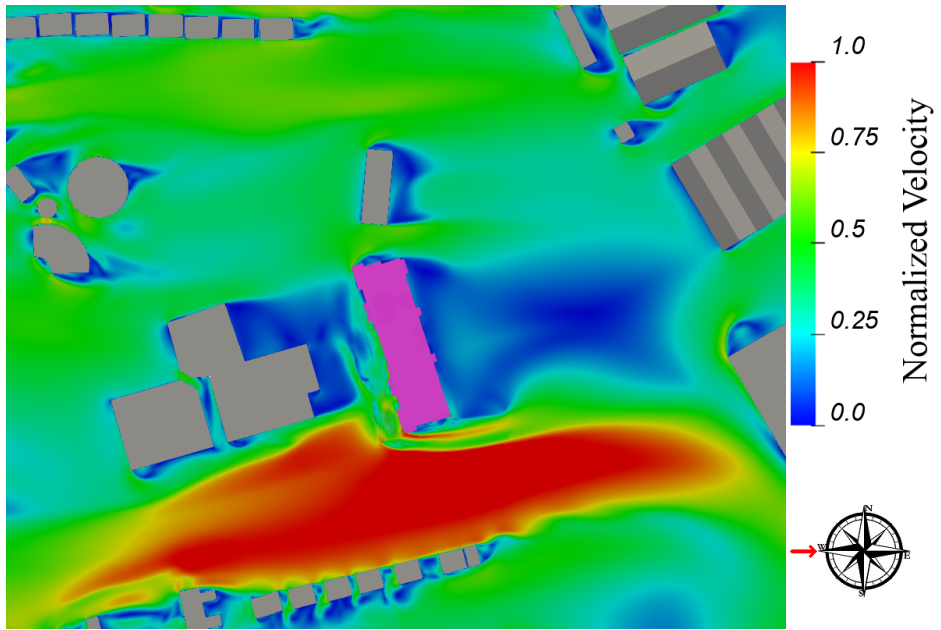

Figure 8.10: Flow Velocity Results at 1.5m above the ground - Wind Direction: 270°

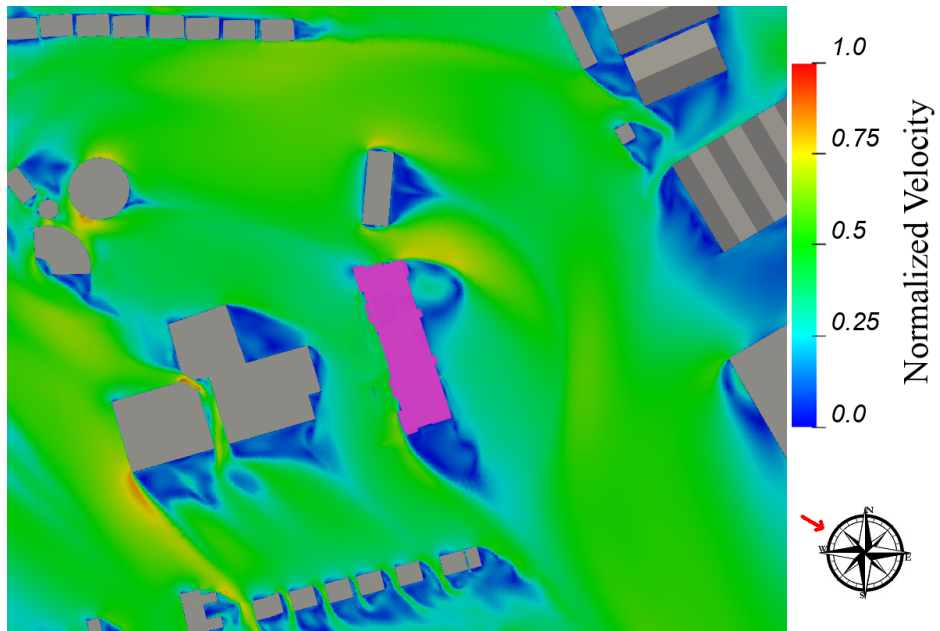

Figure 8.11: Flow Velocity Results at 1.5m above the ground - Wind Direction: 300°

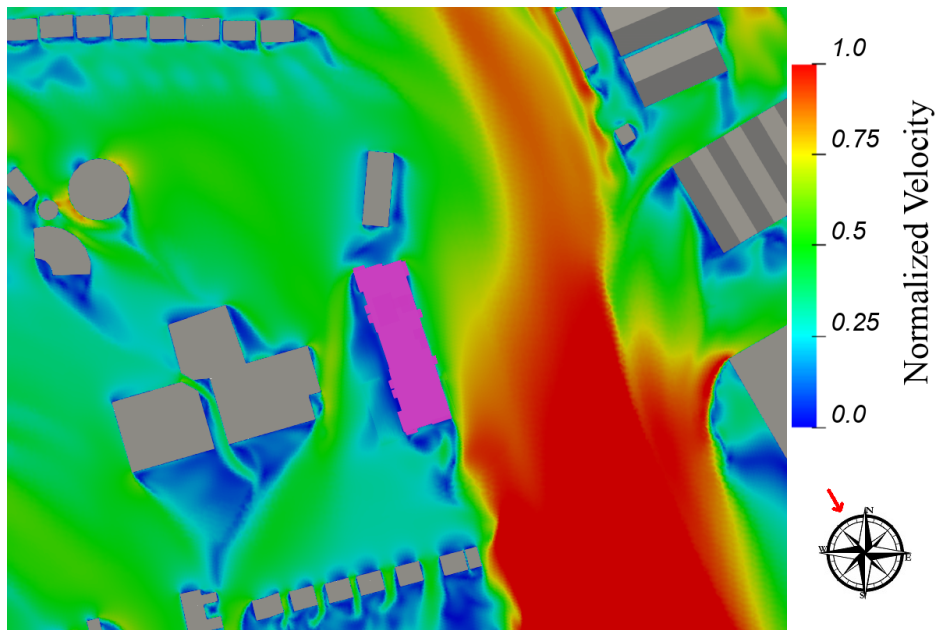

Figure 8.12: Flow Velocity Results at 1.5m above the ground - Wind Direction: 330°

8.2.2 PROPOSED DEVELOPMENT WIND MICROCLIMATE - LAWSON CRITERIA

The wind flow results obtained simulating the different direction and wind speeds, are combined with wind frequencies of occurrence to obtain comfort ratings at pedestrian level in all areas included within the model. The comparison of comfort ratings with intended pedestrian activities is shown in the Lawson Comfort and Distress Map that follows.

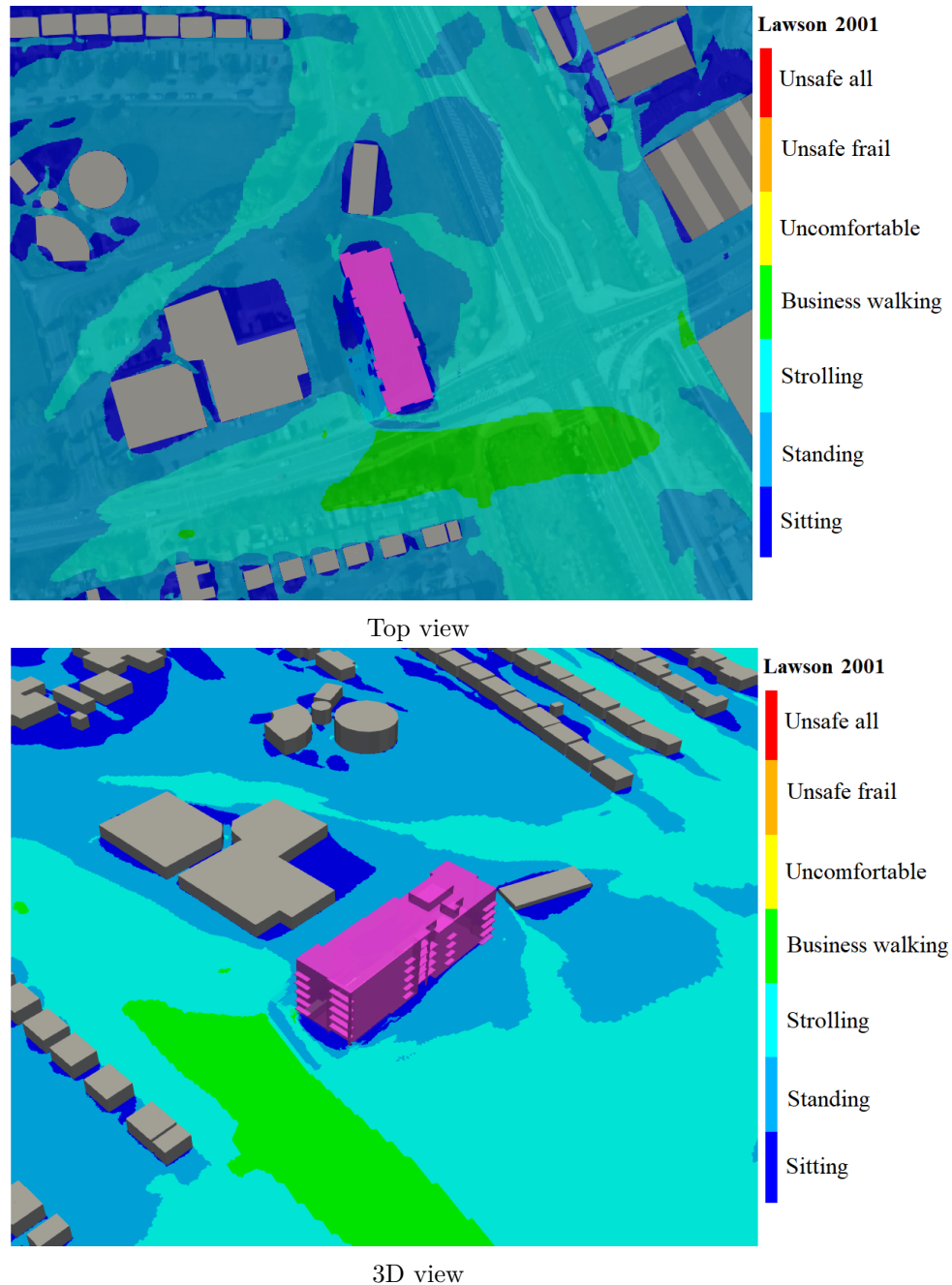

Figure 8.13: Ground Floor - Lawson Discomfort Map - Proposed scenario

8.2.3 BALCONIES

The comparison of comfort ratings with the intended pedestrian activities is depicted in the Lawson Comfort and Distress Map on the 1.5m balcony floor, as illustrated in Figures 8.14 and 8.15. It is evident that all the balconies are deemed safe for occupants, with no distress areas identified.

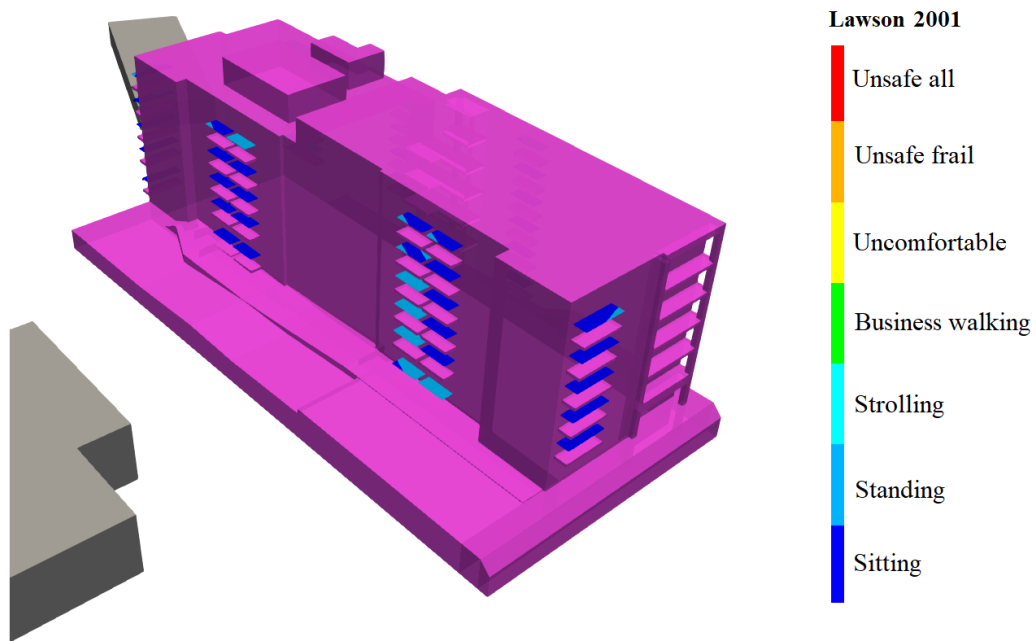

Figure 8.14: Balconies - Lawson Discomfort Map - Proposed scenario

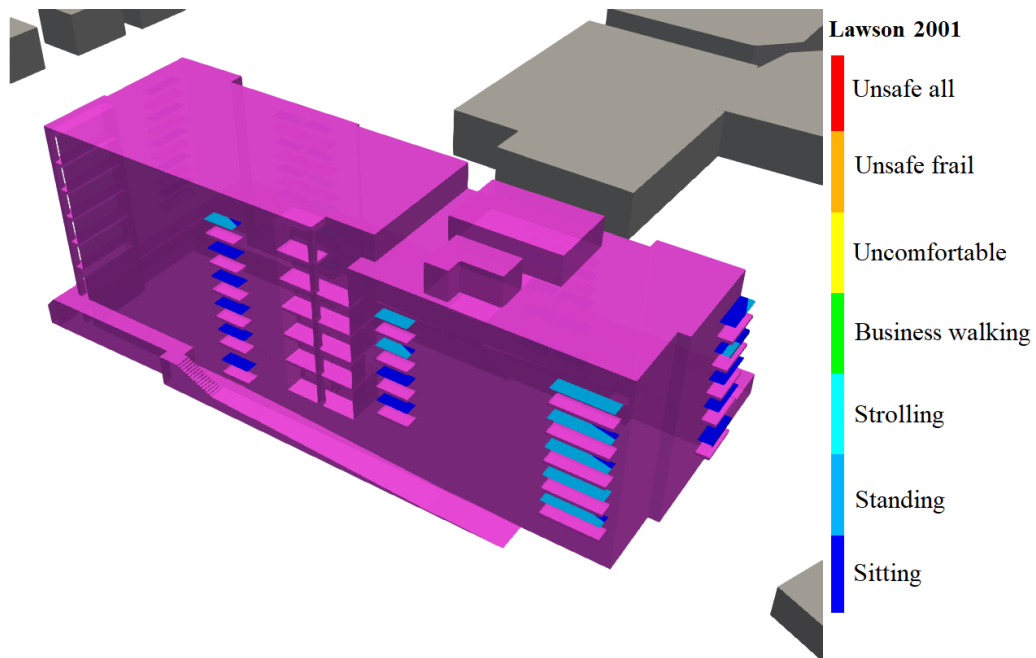

Figure 8.15: Balconies - Lawson Discomfort Map - Proposed scenario

8.2.4 PLANNED MITIGATION

As mentioned in the previous section, there are several wind effects that can occur at the development site, such as downwash and funneling. These phenomena can cause accelerated wind speeds at pedestrian level, leading to potential pedestrian discomfort. In order to address these issues, several mitigation options were evaluated. The chosen options were implemented with the aim of reducing the impact of these wind effects and enhancing pedestrian comfort around the development. To address these wind impacts, architectural and structural modifications were implemented in the form of balconies on the East, West, South, and North sides of the development, with a particular focus on corners and higher elevations away from pedestrian zones. These adjustments can alter the path of the wind before it reaches ground level. Additionally, to further improve pedestrian comfort within the development, existing trees along the walkway on the western side have been preserved, hedge planting has been introduced along the western and northern walls of the pathway, and more trees have been added to the North-West and South-West areas. These measures collectively contribute to mitigating wind impacts at ground floor near the development as shown in Figures 8.16 to 8.17.

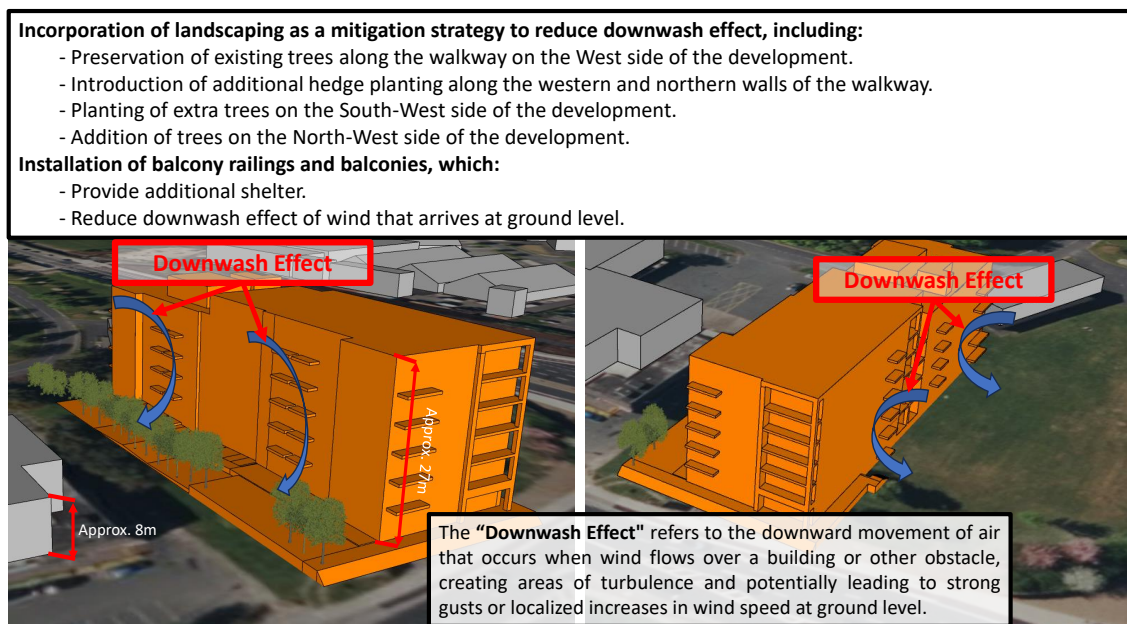

Figure 8.16: Mitigation Measures for Downwash Effect

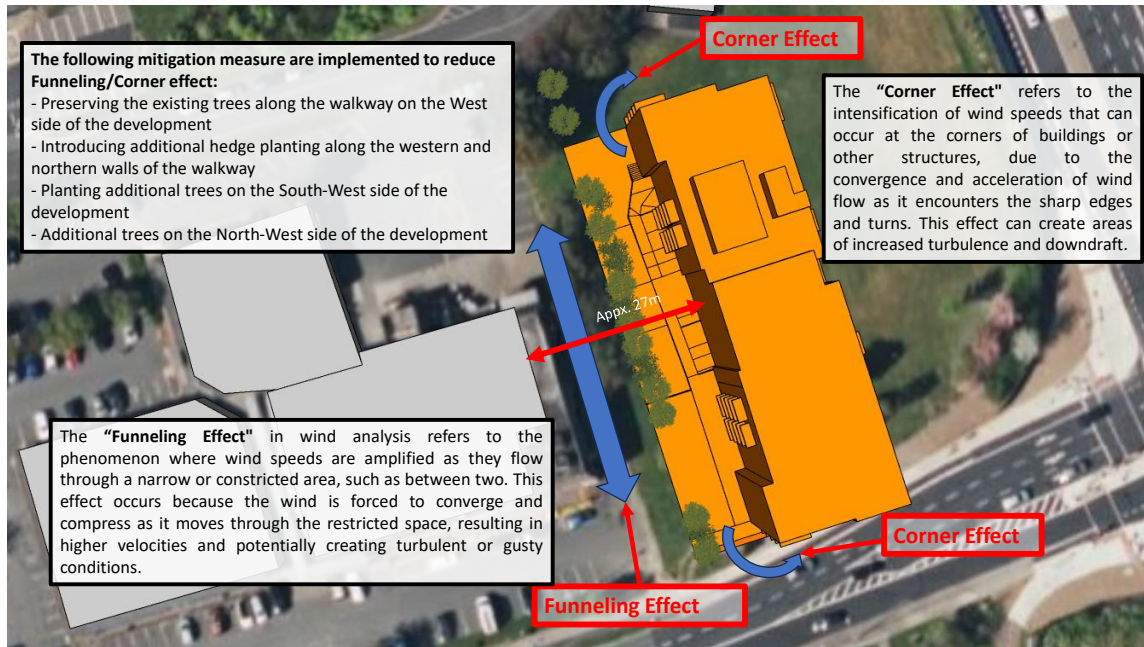

Figure 8.17: Mitigation Measures for Funnelling and Corner Effects

According to the Lawson Map, the receptor area around the development is safe for pedestrians and provides suitable comfort levels for activities such as standing, walking, and strolling. However, it is important to note that the Lawson Map was calculated based on worst-case scenarios without considering hedge planting and tree implementation. The addition of trees and hedges can help mitigate wind impact and enhance pedestrian comfort levels. As shown in Figure 8.18, the following mitigation measures are implemented to improve pedestrian comfort around the development:

- *Preserving the existing trees along the walkway on the west side of the development:*
The presence of these existing trees along the walkway enhances comfort for pedestrians, particularly in the northern part of this area.
- *Introducing additional hedge planting along the western and northern walls of the walkway:*
This additional hedge planting will help reduce wind speed, increasing comfort levels in the playground on the North-West side of the development.
- *Planting additional trees on the South-West side of the development:*
These additional trees can reduce west or southward winds and provide a shield for the playground (Amenity 3) and the southern entrance with its sitting areas (Amenity 4) from the wind.
- *Additional trees on the North-West side of the development:*
Proposed tree planting on the northwestern corner of the development will shield the garage entrance (Amenity 5).
- The balcony railings are acting as wind deflectors, helping to reduce the impact of

wind. This shows that the balconies are designed with considerations for prevailing wind directions.

- The balconies also function as windbreaks, providing additional shelter to pedestrians by blocking or reducing the downwash or corner effects of wind that arrives at ground level.

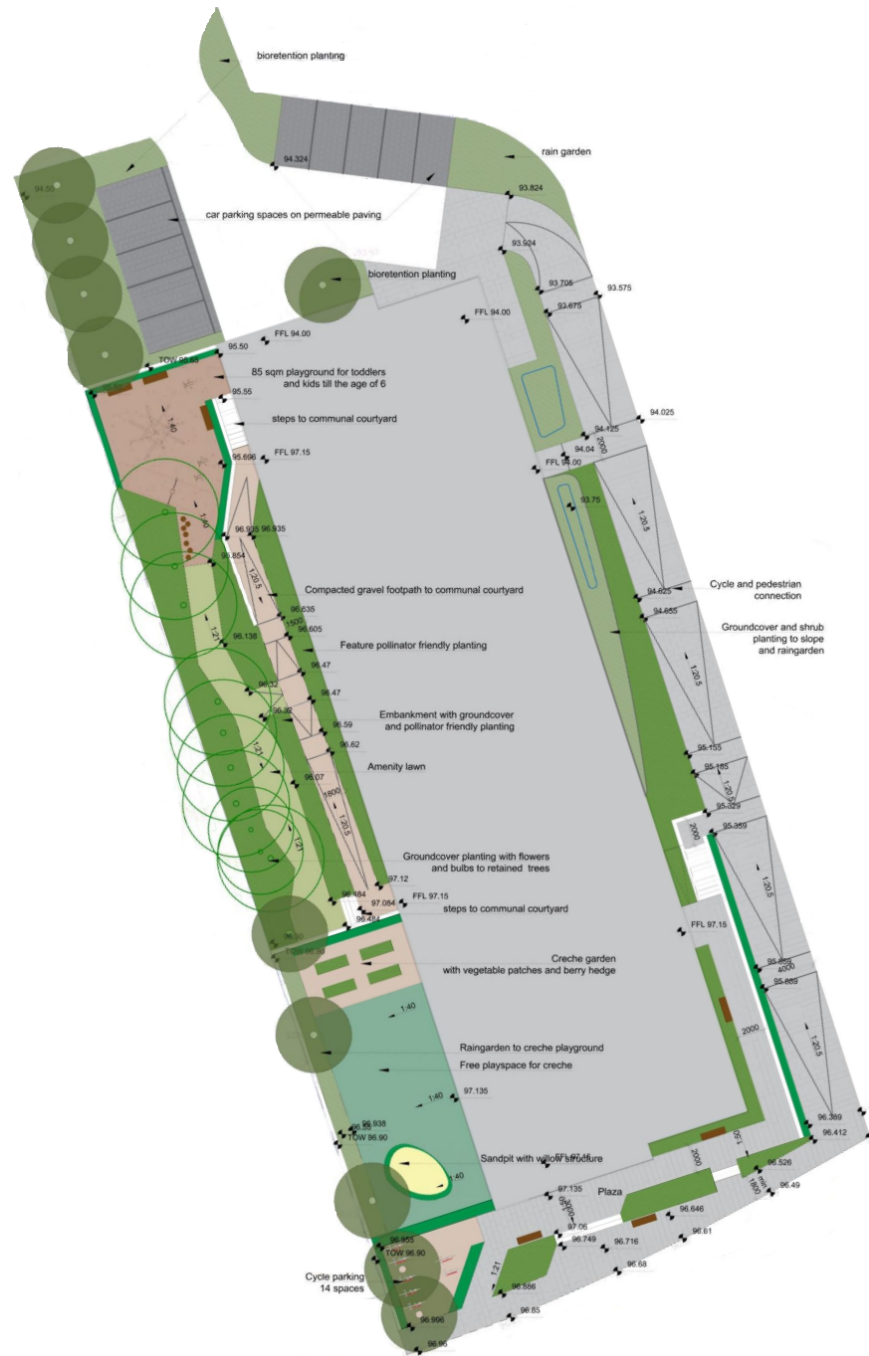

Figure 8.18: Mitigation plans around the development

It is worth noting that no further mitigation measures are required along the eastern side (Amenity 6) of the development as it is already comfortable for the intended use such as sitting/standing comfort level as it can be seen in Figure 8.19.

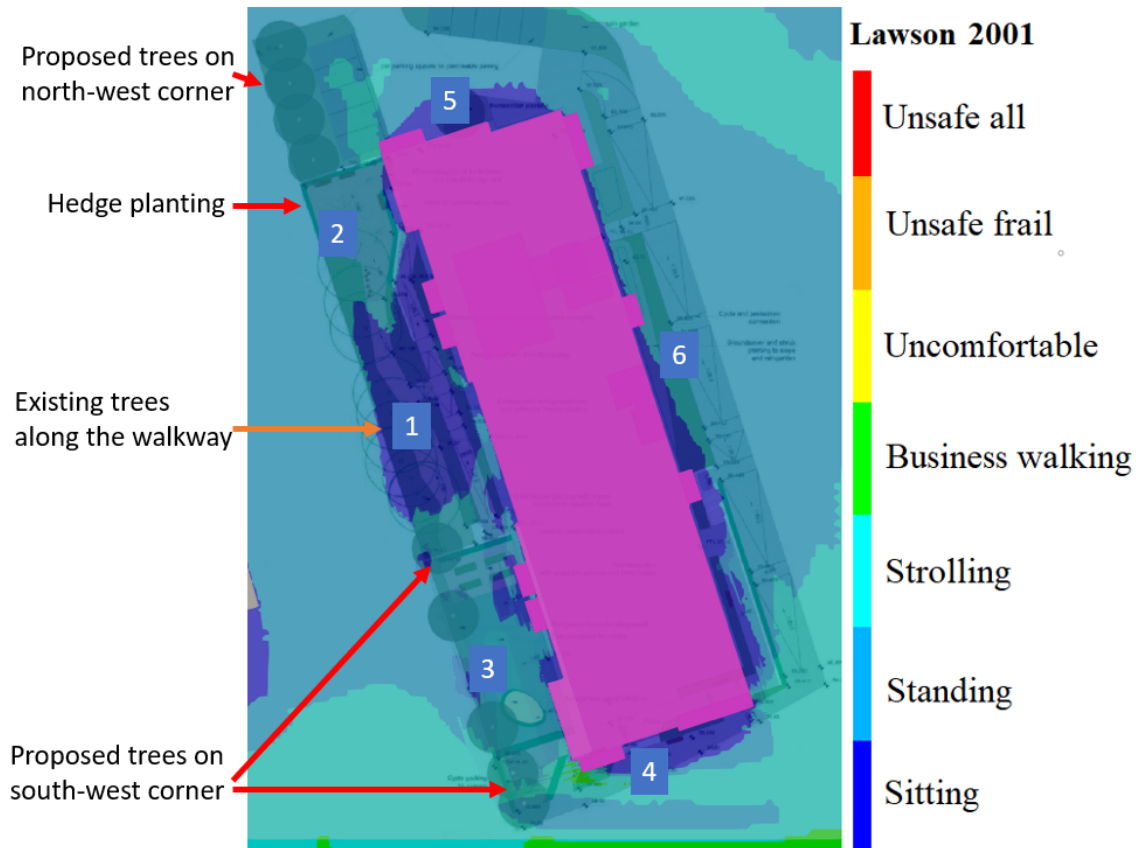
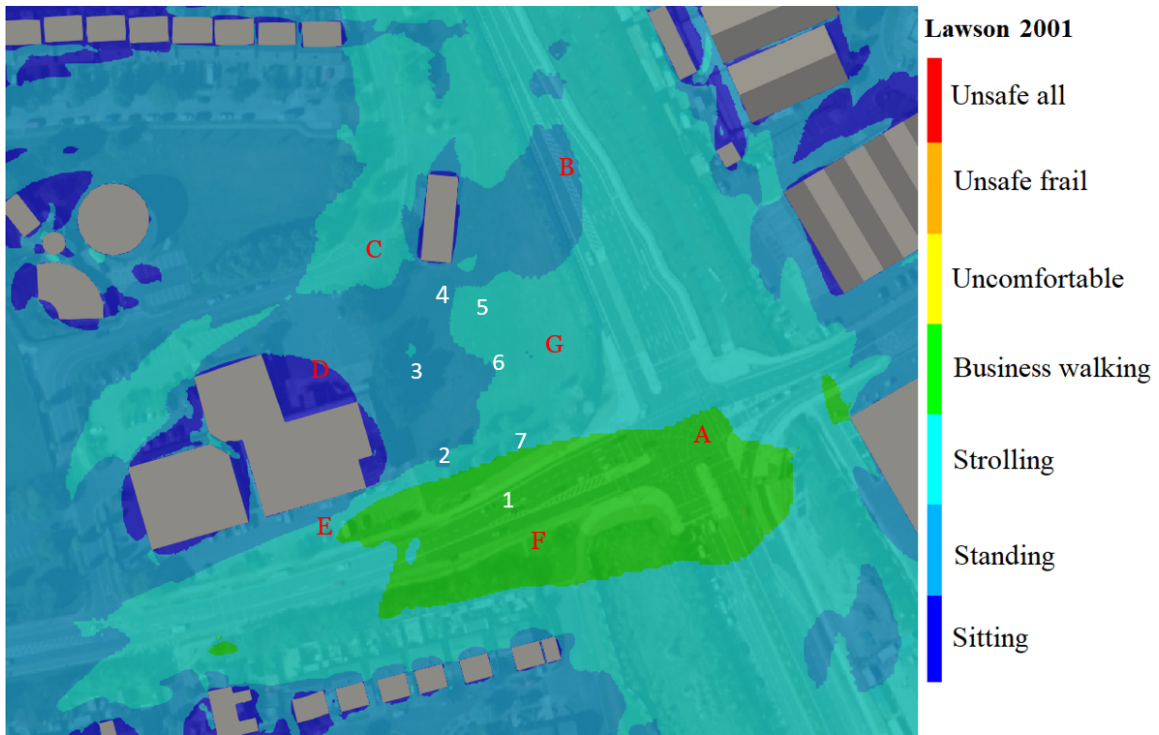

Figure 8.19: Lawson Discomfort Map and mitigation around the development

In summary, the following conclusions can be made observing the results of the wind microclimate analysis and comparing the results obtained, under the same wind conditions for the baseline scenario versus the proposed development scenario:

- The assessment of the proposed scenario has shown that no area is unsafe, and no conditions of distress are created by the proposed development.
- All the roads proposed can be used for their intended scope.
- The wind microclimate of the proposed development is safe and usable for pedestrians.

As a result of the proposed development construction, the wind on the surrounding urban context maintains the suitability of the surrounding urban environment for its intended purpose.



Baseline Scenario

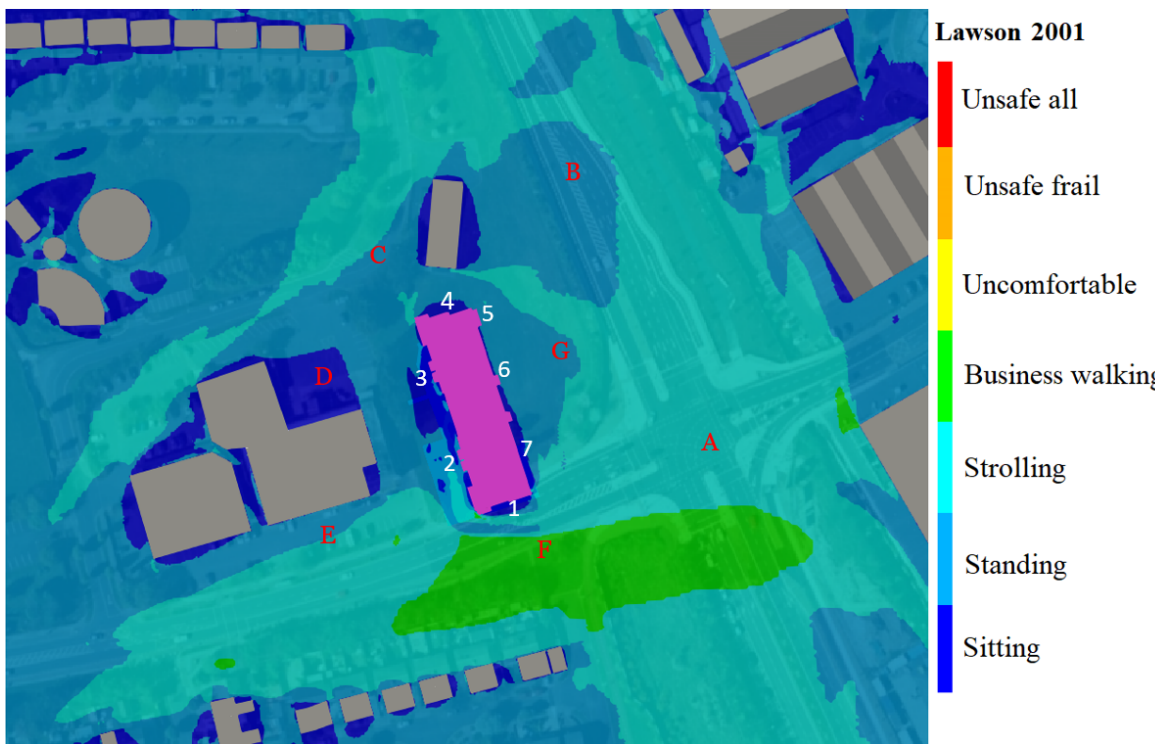

Proposed Development Scenario

Figure 8.20: Comparison Wind Microclimate Conditions (Lawson Comfort/Distress Map)

Table 8.1 presents the pedestrian comfort levels for various on-site and off-site locations. As shown in the table, none of the areas are deemed unsafe, and all on-site receptors around the development are suitable for at least standing comfort level.

Table 8.1: Pedestrian Comfort Levels versus Proposed pedestrian activities

Reference point	Description	Sitting	Standing	Strolling	Business walking	Distress and Safety
1.	South Entrance.	Tolerable.	Tolerable.	Acceptable.	Acceptable.	Safe.
2.	Garden and playground.	-	Tolerable.	Acceptable.	Acceptable.	Safe.
3.	Courtyard.	Tolerable.	Acceptable	Acceptable.	Acceptable.	Safe.
4.	Garage Entrance.	Tolerable.	Acceptable	Acceptable.	Acceptable.	Safe.
5.	Cycle and Pedestrian Connection.	-	Acceptable	Acceptable.	Acceptable.	Safe.
6.	Cycle and Pedestrian Connection.	-	Acceptable	Acceptable.	Acceptable.	Safe.
7.	Cycle and Pedestrian Connection.	Tolerable.	Acceptable	Acceptable.	Acceptable.	Safe.
A.	Crossroad of Blackthorn Dr and Drummartin Link Rd.	-	-	Acceptable.	Acceptable.	Safe.
B.	Drummartin Link Rd.	-	Acceptable	Acceptable.	Acceptable.	Safe.
C.	Maples Rd.	-	Tolerable.	Acceptable.	Acceptable.	Safe.
D.	Parking lot and supply depo.	Acceptable	Acceptable	Acceptable.	Acceptable.	Safe.
E.	Shop entrances.	-	Tolerable.	Acceptable.	Acceptable.	Safe.
F.	Blackthorn Dr.	-	-	-	Acceptable.	Safe.
G.	Lawn.	-	Tolerable.	Acceptable.	Acceptable.	Safe.

Tables 8.2 and 8.3 show the intended baseline and proposed wind conditions on-site as well as some potential off-site receptors around the development. Locations of the ground amenity areas listed in these Tables are indicated in Figure 8.21.

Table 8.2: Significance Impact of the Proposed Development Versus Baseline Conditions for Comfort - On Site Receptors

On-Site Potential Receptors	Baseline Conditions	Proposed Development Conditions	Impact Significance
1. South Entrance	Suitable for Walking.	Suitable for Standing/Strolling. (Safe/No distress)	Negligible
2. Garden and playground.	Suitable for Standing/Strolling.	Suitable for Standing/Strolling. (Safe/No distress)	Negligible
3. Courtyard.	Suitable for Standing.	Suitable for Sitting/Standing. (Safe/No distress)	Negligible
4. Garage Entrance.	Suitable for Standing/Strolling.	Suitable for Sitting/Standing. (Safe/No distress)	Negligible
5. Cycle and Pedestrian Connection.	Suitable for Strolling.	Suitable for Standing. (Safe/No distress)	Negligible
6. Cycle and Pedestrian Connection.	Suitable for Standing/Strolling.	Suitable for Standing. (Safe/No distress)	Negligible
7. Cycle and Pedestrian Connection.	Suitable for Strolling/Walking.	Suitable for Sitting/Standing. (Safe/No distress)	Negligible

Table 8.3: Significance Impact of the Proposed Development Versus Baseline Conditions for Comfort - Off Site Receptros

Off-Site Potential Receptors	Baseline Conditions	Proposed Development Conditions	Impact Significance
A. Crossroad of Blackthorn Dr and Drummartin Link Rd.	Suitable for Strolling/Walking.	Suitable for Strolling. (Safe/No distress)	Negligible
B. Drummartin Link Rd.	Suitable for Standing.	Suitable for Standing. (Safe/No distress)	Negligible
C. Maples Rd.	Suitable for Strolling.	Suitable for Standing/Strolling. (Safe/No distress)	Negligible
D. Parking lot and supply depo.	Suitable for Sitting/Standing.	Suitable for Standing. (Safe/No distress)	Negligible
E. Shop entrances.	Suitable for Standing/Strolling.	Suitable for Standing/Strolling. (Safe/No distress)	Negligible
F. Blackthorn Dr	Suitable for Walking.	Suitable for Walking. (Safe/No distress)	Negligible
G. Lawn.	Suitable for Strolling.	Suitable for Standing/Strolling. (Safe/No distress)	Negligible

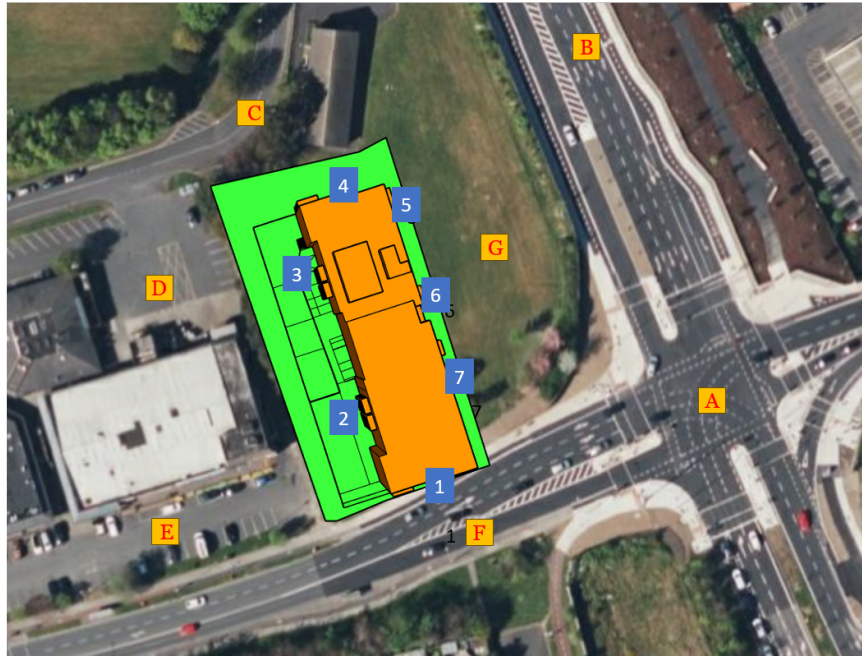

Figure 8.21: Locations of the Ground Amenities

As shown in Tables 8.2 and 8.3, there are no distress area for pedestrians including frail users and cyclist. furthermore, the site and surrounding urban areas are safe for all users.

9. CONCLUSIONS

CONCLUSIONS AND COMMENTS ON MICROCLIMATE STUDY

This report presents the CFD modelling assumptions and results of Wind and Microclimate Modelling of the Proposed Part 8 Residential Development, Balally, Blackthorn Drive, Sandyford, Dublin 16.

This study has been carried out to identify the possible wind patterns around the area proposed, under mean and peak wind conditions typically occurring in Dublin City, and also to assess impacts of the wind on pedestrian levels of comfort/distress.

The results of this wind microclimate study are utilized by on behalf of the NDFA and Dun Laoghaire County Council to configure the optimal layout for the Proposed Part 8 Residential Development for the aim of achieving a high-quality environment for the scope of use intended of each areas/building (i.e. comfortable and pleasant for potential pedestrian) and not to introduce any critical wind impact on the surrounding areas and on the existing buildings.

- The wind profile was built using the annual average meteorological data for Dublin Airport, which was obtained from Meteoblue. The local wind speed was determined from CFD simulations with combination of the parameters inside Weibull probability distribution function, which was obtained from historical meteorological data recorded 10m above ground level.
- A 12-discrete set of wind direction is used in order to evaluate the probability of exceedance at any given threshold speed. It is found that the prevailing wind direction in the West has the largest contribution of the discomfort exceedance probability.
- The microclimate Assessment of the Proposed Part 8 Residential Development and its environment was performed utilizing a CFD (Computational Fluid Dynamics) methodology.
- The evaluation of the proposed scenario indicates that the planned development aligns with the Lawson Comfort Criteria, confirming that no areas are unsafe and the proposed development does not create conditions of distress. All the ground and the courtyard amenities outlined in the report can be utilized according to their intended scope.
- The Lawson Comfort and Distress Map on the 1.5m above balcony floor indicates that all balconies are safe for occupants with no identified distress areas.
- Following mitigation measures will be implemented to further improve pedestrian comfort around the development:
 - Preserving the existing trees along the walkway on the West side of the development;
 - Introducing additional hedge planting along the western and northern walls of the walkway;
 - Planting additional trees on the South-West side of the development;
 - Additional trees on the North-West side of the development;
 - The balcony railings are acting as wind deflectors, helping to reduce the impact

of wind. This shows that the balconies are designed with considerations for prevailing wind directions;

- The balconies also function as windbreaks, providing additional shelter to pedestrians by blocking or reducing the downwash or corner effects of wind that arrives at ground level.
- As a result of the proposed development construction, the wind on the surrounding urban context remains suitable for the intended use when compared with the baseline situation.
- The proposed development does not impact or give rise to negative or critical wind speed profiles at the nearby adjacent roads, or nearby buildings. Moreover, in terms of distress, no critical conditions were found for “Frail persons or cyclists” and for members of the “General Public” in the surrounding of the development.

Therefore, the CFD study carried out has shown that under the assumed wind conditions typically occurring within Dublin city for the past 15 years:

- **The development is designed to be a high-quality environment for the scope of use intended of each areas/building (i.e. comfortable and pleasant for potential pedestrian), and,**
- **The development does not introduce any critical impact on the surrounding buildings, or nearby adjacent roads.**

10. REFERENCES

- Lawson, T.V., 2001, 'Building Aerodynamics', Imperial College Press, London
- Simiu, E., 2011, 'Design of buildings for wind: a guide for ASCE 7-10 Standard users and designers of special structures', 2nd Edition, John Wiley and Sons, Inc., Hoboken, New Jersey, U.S.A.
- Building Aerodynamics, Tom Lawson FREng. Imperial College Press, 2001
- Blocken, B., 2015. Computational Fluid Dynamics for Urban Physics: Importance, scales, possibilities, limitations and ten tips and tricks towards accurate and reliable simulations. Building and Environment.
- Blocken, B., Janssen, W.D. and van Hooff, T., 2012. CFD simulation for pedestrian wind comfort and wind safety in urban areas: General decision framework and case study for the Eindhoven University campus. Environmental Modelling and Software, 30, pp.15–34.
- Franke, J., Hellsten, A., Schlünzen, H., Carissimo, B., 2007, COST Action 732: Quality Assurance and Improvement of Micro-Scale Meteorological Models, In Best practice guideline for the CFD simulation of flows in the urban environment, COST Office, Belgium.